

# ECE/CS 5745/6745: Testing & Verification of Digital Circuits

Prepared by *Priyank Kalla*

Fall 2023, Homework # 1

Due Date: Wednesday Sept. 6, 11:59pm, on Canvas.

**Note:** The HWs should be uploaded by students electronically on Canvas.

- 1) (25 points) Are the following statements TRUE or FALSE? If the statement is TRUE, prove it. Otherwise, show a counter-example. No points for just stating TRUE, FALSE.
  - a) The Shannon's expansion of  $f$  w.r.t. variable  $x$  can be given as  $f = (x + f_{\bar{x}})(\bar{x} + f_x)$ .
  - b) The Shannon's expansion of  $f$  w.r.t.  $x$  can also be given as  $f = x \cdot f_x \oplus \bar{x} \cdot f_{\bar{x}}$ , where  $\oplus$  denotes the XOR operation.
  - c)  $\bar{f} = x \cdot \overline{(f_x)} + \bar{x} \cdot \overline{(f_{\bar{x}})}$ .
  - d) Let  $f$  be a Boolean function, and  $x$  be a variable in its support. To check whether  $f$  is TAUTOLOGY, it is *necessary and sufficient* to check if both its cofactors  $f_x, f_{x'}$  are TAUTOLOGY.
  - e) Given a Boolean function  $f$  that is *positive unate* in variable  $x$ . To check if  $f$  is TAUTOLOGY, it is *sufficient* to check that its negative cofactor  $f_{x'}$  is TAUTOLOGY.
- 2) (15 points) For the circuit shown in Fig. 1, using the method of Boolean differences, identify the set of all assignments to the input variables that allow to propagate the changes on signal  $a$  to the output  $Z$ .

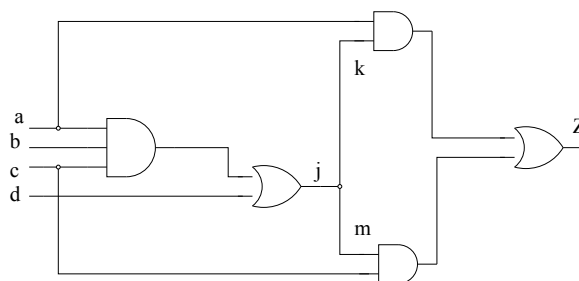

Fig. 1: Is  $Z$  sensitive to changes in  $a$ ?

- 3) (20 points) We know that the Shannon's expansion of  $f$  w.r.t. variable  $x$  is given as  $f = x \cdot f_x + x' \cdot f_{x'}$ . This expansion corresponds to an AND-OR-NOT representation. Notice that the Boolean operators in Shannon's expansion include AND, OR as well as NOT gates. You

also know that any Boolean function can be implemented using AND-OR-NOT gates (universal logic); thus, Shannon's expansion can also be universally applied.

- Starting from the Shannon's expansion, you are asked to derive the following expansion, called the *positive-Davio expansion*:  $f = f_{x'} \oplus x \cdot (f_x \oplus f_{x'})$ , where  $\oplus$  represents the XOR operation. Notice that in the Davio's expansion, you only see AND and XOR operations. Some of you will recall that AND-XOR is also universal logic. If you're unaware of AND-XOR being universal logic, then please take a look at the slides on universal logic that I have uploaded on the class webpage at <https://my.ece.utah.edu/~kalla/ECE6745/ch2-universal-logic.pdf>. You may also watch the corresponding video in the Media Gallery on Canvas. Davio expansion can be used to implement any Boolean function using AND and XOR gates only.
- Implement the Boolean function  $f = ab + \bar{a}c$  as a logic circuit using only AND and XOR gates.
- Derive the *negative Davio decomposition*:  $f = f_x \oplus \bar{x} \cdot (f_x \oplus f_{x'})$ .

- 4) (10 points) Let  $f = a'b'c' + a'b'c + a'bc' + ab'c'$ . Identify the component of the function  $f$  that is independent of variable  $b$ . What is this operation called?
- 5) (10 points) Given the function  $f = a'b'c' + a'b'c + a'bc' + ab'c'$  (the same as above), find the smallest function, larger than  $f$ , that contains  $f$ , but does not contain the variable  $b$  in its support. What is this operation called?
- 6) (20 points) Let  $f = a'b' + b'c + ab$ . Let  $g = ac$ . You are asked to check if  $g \subset f$ ? Using an appropriate formulation that we have discussed in class, perform this containment check. Describe your formulation, show your work and state your answer whether  $g \subset f$ . [Hint: Remember, I showed you in class, the relationship between containment and tautology?]

# ECE/CS 5745/6745: Testing & Verification of Digital Circuits

Prepared by *Priyank Kalla*

Fall 2023, Homework # 1

Due Date: Wednesday Sept. 6, 11:59pm, on Canvas.

**Note:** The HWs should be uploaded by students electronically on Canvas.

- 1) (25 points) Are the following statements TRUE or FALSE? If the statement is TRUE, prove it. Otherwise, show a counter-example. No points for just stating TRUE, FALSE.

- a) The Shannon's expansion of  $f$  w.r.t. variable  $x$  can be given as  $f = (x + f_{\bar{x}})(\bar{x} + f_x)$ .

$$f = (x + f_{\bar{x}})(\bar{x} + f_x)$$

$$= x\bar{x} + x.f_x + \bar{x}f_{\bar{x}} + f_{\bar{x}}f_x$$

$$= \overset{\rightarrow 0}{x\bar{x}} + \bar{x}f_{\bar{x}} + f_xf_{\bar{x}}$$

$$= \bar{x}f_{\bar{x}} + f_xf_{\bar{x}} + (x + \bar{x})(f_x + f_{\bar{x}})$$

$$= \bar{x}f_{\bar{x}} + f_xf_{\bar{x}} + xf_x + \bar{x}f_{\bar{x}}$$

$$= \bar{x}f_{\bar{x}} + f_xf_{\bar{x}} \rightarrow \text{TRUE}$$

b) The Shannon's expansion of  $f$  w.r.t.  $x$  can also be given as  $f = x \cdot f_x \oplus \bar{x} \cdot \bar{f}_x$ , where  $\oplus$  denotes the XOR operation.

$$\begin{aligned}
 f &= x f_x \oplus \bar{x} \bar{f}_x \\
 &= x f_x (\overline{\bar{x} \bar{f}_x}) \\
 &\quad + \bar{x} \bar{f}_x (\overline{x f_x}) \\
 &= x f_x (x + \bar{f}_x) \\
 &\quad + \bar{x} \bar{f}_x (\bar{x} + f_x)
 \end{aligned}$$

$$\left[ \begin{aligned} a \oplus b \\ = a\bar{b} + \bar{a}b \end{aligned} \right]$$

[DEMORGAN'S LAW]

$$\begin{aligned}
 &= x f_x + x f_x \bar{f}_x + \bar{x} \bar{f}_x + \bar{x} \bar{f}_x f_x \\
 &= x f_x (1 + \bar{f}_x) + \bar{x} \bar{f}_x (1 + f_x) \\
 &= x f_x + \bar{x} \bar{f}_x
 \end{aligned}$$

TRUE

c)  $\bar{f} = x \cdot \overline{(f_x)} + \bar{x} \cdot \overline{(\bar{f}_x)}$ .

$$f = x f_x + \bar{x} \bar{f}_x$$

$$\begin{aligned}
 \therefore \bar{f} &= \overline{(x f_x + \bar{x} \bar{f}_x)} = \overline{(x f_x)} \overline{(\bar{x} \bar{f}_x)} \\
 &= (\bar{x} + \bar{f}_x) (\overline{x + f_x}) \\
 &= x \bar{f}_x + \bar{x} \bar{f}_x + \bar{f}_x \bar{x} \\
 &= x \bar{f}_x + \bar{x} \bar{f}_x + \overline{(f_x + f_x)}
 \end{aligned}$$

Now let's apply Shannon's expansion here:

$$\begin{aligned}\bar{f}(x=1) &= \bar{f}_x + \bar{f}_x \bar{f}_a \\ &= \bar{f}_x (1 + \bar{f}_a) = \bar{f}_x\end{aligned}$$

$$\begin{aligned}\bar{f}(x=0) &= \bar{f}_a + \bar{f}_x \bar{f}_a = \bar{f}_a (1 + \bar{f}_x) \\ &= \bar{f}_a\end{aligned}$$

Hence we can see that  $\bar{f}_x \bar{f}_a$  is a redundant term since it is already contained in  $x\bar{f}_x + \bar{x}\bar{f}_a$

So we can ignore this term & we get

$$\bar{f} = x\bar{f}_x + \bar{x}\bar{f}_a \quad \text{TRUE}$$

ex:  $f = ab + ac + bc$

$$\bar{f} =$$

<del>a</del>	bc	00	01	11	10
0		1	1		1
1		1	1		1

$$x\bar{f}_x = a(\overline{b+c}) = a(\bar{b} \cdot \bar{c}) = \boxed{\bar{a}\bar{b}\bar{c}}$$

$$\bar{x}\bar{f}_a = \bar{a}(bc) = \bar{a}(\bar{b} + \bar{c}) = \boxed{\bar{a}\bar{b} + \bar{a}\bar{c}}$$

$$\bar{f}_x \bar{f}_a = (\overline{b+c})(\bar{b}\bar{c}) = (\bar{b} \cdot \bar{c})(\bar{b} + \bar{c}) = \boxed{\bar{b}\bar{c}}$$

Now let's look at the K map:

a \ bc	00	01	11	10
0	1	1		1
1	1			

already contained

d) Let  $f$  be a Boolean function, and  $x$  be a variable in its support. To check whether  $f$  is TAUTOLOGY, it is *necessary and sufficient* to check if both its cofactors  $f_x, f_{\bar{x}}$  are TAUTOLOGY.

Sufficient cond:

$f_x, f_{\bar{x}} \rightarrow$  both tautology

Let's say  $f_x = 1$  &  $f_{\bar{x}} = 1$

$$\begin{aligned} \text{then } f &= x \cdot f_x + \bar{x} \cdot f_{\bar{x}} \\ &= x + \bar{x} = 1 \end{aligned}$$

hence we can see that it is sufficient to check if  $f_x, f_{\bar{x}}$  are tautology

## Necessary cond :

Now to prove necessary cond let's assume that  $f_x$  is not tautology

$$\text{so, } f = x(\dots) + \bar{x}f_{\bar{x}}$$

let's assume  $f_{\bar{x}} = 1$  since tautology

$$\therefore f = x(\dots) + \bar{x} \cdot 1 = x(\dots) + \bar{x}$$

$$\Rightarrow f = x(\dots) + \bar{x} \neq 1$$

This could never result in  $f=1$  if  $f_x$  is not tautology itself

- e) Given a Boolean function  $f$  that is *positive unate* in variable  $x$ . To check if  $f$  is TAUTOLOGY, it is *sufficient* to check that its negative cofactor  $f_{\bar{x}}$  is TAUTOLOGY.

$f = +ve \text{ unate}$  hence that means  $f_x \supset f_{\bar{x}}$

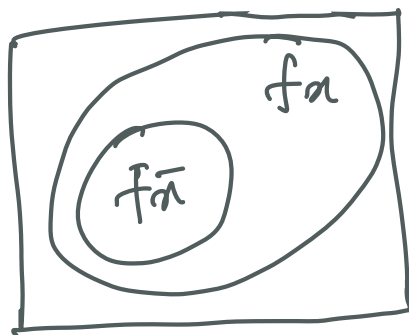

Since we already proved that for  $f$  to be tautology it is necessary & sufficient to check if  $f_x$  &  $f_{\bar{x}}$  are tautology or not

Since  $f_x \supset f_{\bar{x}}$  we only need to check if  $f_{\bar{x}}$  is tautology or not [The bigger set containing the smaller set will automatically become tautology if smaller one is tautology]

- 2) (15 points) For the circuit shown in Fig. 1, using the method of Boolean differences, identify the set of all assignments to the input variables that allow to propagate the changes on signal  $a$  to the output  $Z$ .

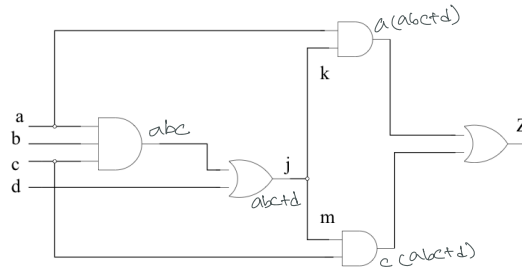

Fig. 1: Is  $Z$  sensitive to changes in  $a$ ?

$$Z = a(abc+d) + c(abc+d)$$

$$= (a+c)(abc+d)$$

To check whether or not  $Z$  is sensitive to changes in 'a' we have to determine the boolean diff respect to 'a'.

$$\frac{\partial Z}{\partial a} = Z_a \oplus Z_{\bar{a}}$$

$$= (bc+d) \oplus cd$$

$$= (bc+d)(\overline{cd}) + cd(\overline{bc+d})$$

$$= (bc+d)(\bar{c} + \bar{d}) + cd(\overline{bc} \cdot \bar{d})$$

$$= \bar{c}d + bc\bar{d}$$

Hence we can conclude that  $Z$  is sensitive to the changes in  $a$

Now let us apply inputs as  $\{bc\bar{d} + \bar{c}d\}$

$$\rightarrow \{110, x01\}$$

We can see that for these input combinations the changes in 'a' will be propagated to  $Z$  i.e.

$$(a+c)(abc+d)$$

$$= abc+ad$$

$$+ abc+cd$$

$$= abc+ad+cd$$



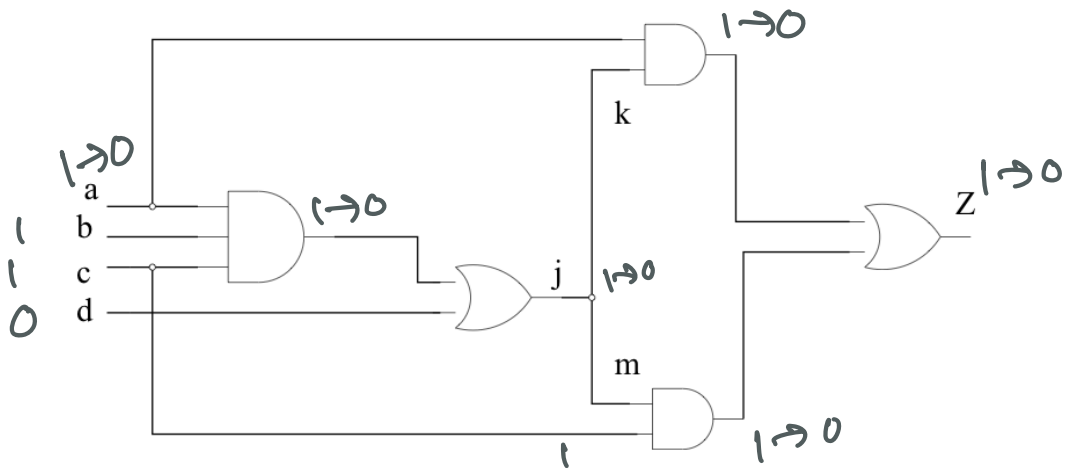

with any other input combinations such as  $abcd \rightarrow 1111$  or  $0000$  we won't be able to catch the change; for ex, but  $bed = 000$

2.

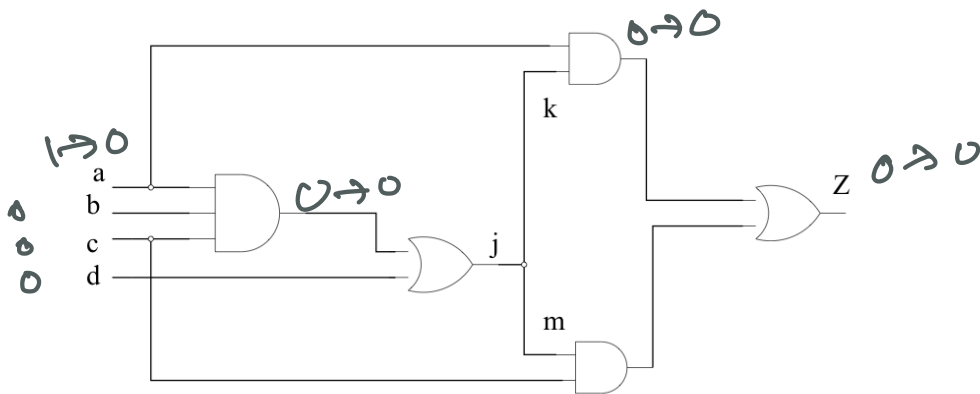

3) (20 points) We know that the Shannon's expansion of  $f$  w.r.t. variable  $x$  is given as  $f = x \cdot f_x + x' \cdot f_{x'}$ . This expansion corresponds to an AND-OR-NOT representation. Notice that the Boolean operators in Shannon's expansion include AND, OR as well as NOT gates. You

2

also know that any Boolean function can be implemented using AND-OR-NOT gates (universal logic); thus, Shannon's expansion can also be universally applied.

- Starting from the Shannon's expansion, you are asked to derive the following expansion, called the *positive-Davio expansion*:  $f = f_{x'} \oplus x \cdot (f_x \oplus f_{x'})$ , where  $\oplus$  represents the XOR operation. Notice that in the Davio's expansion, you only see AND and XOR operations. Some of you will recall that AND-XOR is also universal logic. If you're unaware of AND-XOR being universal logic, then please take a look at the slides on universal logic that I have uploaded on the class webpage at <https://my.ece.utah.edu/~kalla/ECE6745/ch2-universal-logic.pdf>. You may also watch the corresponding video in the Media Gallery on Canvas. Davio expansion can be used to implement any Boolean function using AND and XOR gates only.
- Implement the Boolean function  $f = ab + \bar{a}c$  as a logic circuit using only AND and XOR gates.
- Derive the *negative Davio decomposition*:  $f = f_x \oplus \bar{x} \cdot (f_x \oplus f_{x'})$ .

Shannon's expansion  $\rightarrow$  positive Davio expr

$$\begin{aligned}
 f &= xfa + \bar{x}f\bar{a} \\
 &= xfa \oplus \bar{x}f\bar{a} \\
 &= xfa \oplus (1 \oplus x)f\bar{a} \\
 &= xfa \oplus f\bar{a} \oplus xf\bar{a} \\
 &= f\bar{a} \oplus x \cdot (fa \oplus f\bar{a})
 \end{aligned}$$

Implementing AND XOR

$$f = ab + \bar{a}c$$

$$fa = b \quad f\bar{a} = c$$

$$a \oplus b = \bar{a}b + a\bar{b}$$

$$f = c \oplus a(b \oplus c)$$

$$\begin{aligned} & \bar{c} \{ a(\bar{b}c + b\bar{c}) \} + c \{ \overline{a(b \oplus c)} \} \\ &= \bar{c} \{ a\bar{b}c + ab\bar{c} \} + c \{ \bar{a} + b\bar{c} \} \\ &= ab\bar{c} + c \{ \bar{a} + b\bar{c} \} \\ &= ab\bar{c} + \bar{a}c + bc \\ &= ab + \bar{a}c \end{aligned}$$

a \ bc	00	01	11	10
0		1	1	
1			1	1

Negative Davio decomposition

$$\begin{aligned} f &= xfa + \bar{x}f\bar{x} \\ &= xfa \oplus \bar{x}f\bar{x} \\ &= (1 \oplus \bar{x})fa \oplus \bar{x}f\bar{x} \\ &= fa \oplus \bar{x}fa \oplus \bar{x}f\bar{x} \\ &= fa \oplus \bar{x}(fa \oplus f\bar{x}) \end{aligned}$$

- 4) (10 points) Let  $f = a'b'c' + a'b'c + a'bc' + ab'c'$ . Identify the component of the function  $f$  that is independent of variable  $b$ . What is this operation called?

Consensus:

$$f_b = \bar{a}\bar{c}$$

$$f_{\bar{b}} = \bar{a}\bar{c} + \bar{a}c + a\bar{c}$$

$$\begin{aligned} f_b \cdot f_{\bar{b}} &= \bar{a}\bar{c} (\bar{a}\bar{c} + \bar{a}c + a\bar{c}) \\ &= \bar{a}\bar{c} \end{aligned}$$

- 5) (10 points) Given the function  $f = a'b'c' + a'b'c + a'bc' + ab'c'$  (the same as above), find the smallest function, larger than  $f$ , that contains  $f$ , but does not contain the variable  $b$  in its support. What is this operation called?

Smoothing:

$$f_b + f_{\bar{b}} = \bar{a}\bar{c} + \bar{a}c + a\bar{c}$$

- 6) (20 points) Let  $f = a'b' + b'c + ab$ . Let  $g = ac$ . You are asked to check if  $g \subset f$ ? Using an appropriate formulation that we have discussed in class, perform this containment check. Describe your formulation, show your work and state your answer whether  $g \subset f$ . [Hint: Remember, I showed you in class, the relationship between containment and tautology?]

$$f = \bar{a}\bar{b} + \bar{b}c + ab$$

$$g = ac$$

$a \backslash bc$	00	01	11	10
0	1	1		
1		1	1	1

$a \backslash bc$	00	01	11	10
0				
1		1	1	

if  $g \subset f$  then that means

$$\bar{g} + f = 1$$

Hence to check this we have to see if  $\bar{g} + f = 1$  or not

a \ bc	00	01	11	10
0	$f\bar{g}$	$f\bar{g}$	$\bar{g}$	$\bar{g}$
1	$\bar{g}$	$f$	$f$	$f\bar{g}$

As we can see from the K map that  $\bar{g} + f = 1$  hence  $g \subset f$  surely

