

Pulsed Neural Networks

Neil E. Cotter

ECE Department
University of Utah

Challenging Problems

Artificial Neural Networks

Learning

Dynamic Networks

Pulsed Networks

Applications

Challenging Problems

Image recognition in varied settings



Speech recognition in noise



Robotic control and navigation

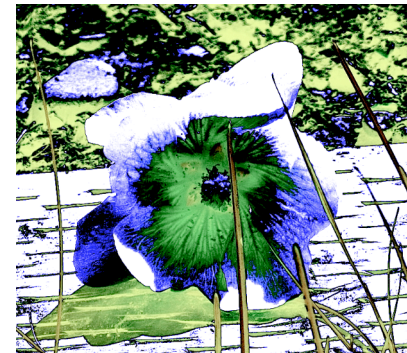

Artificial Neural Networks

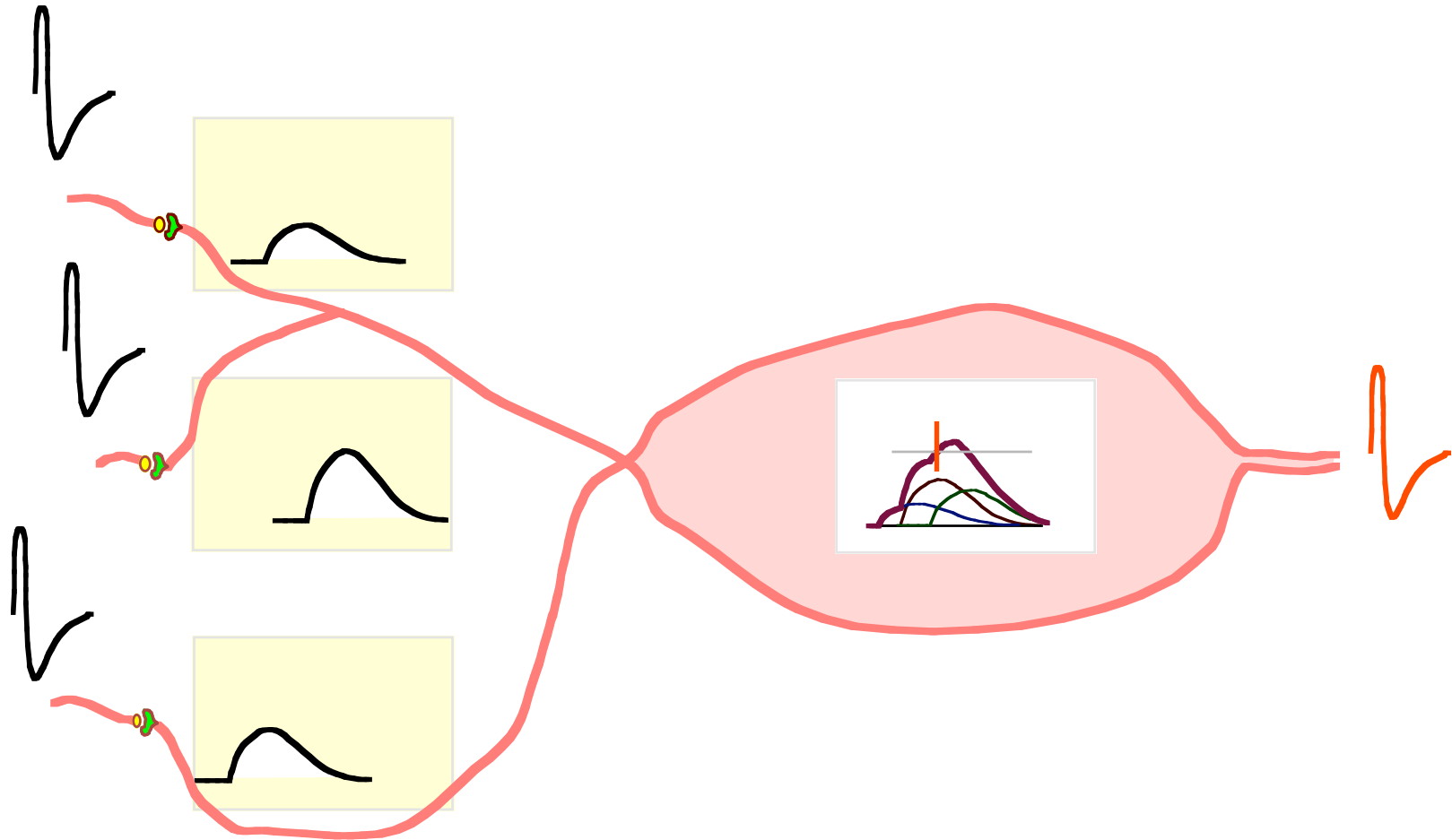

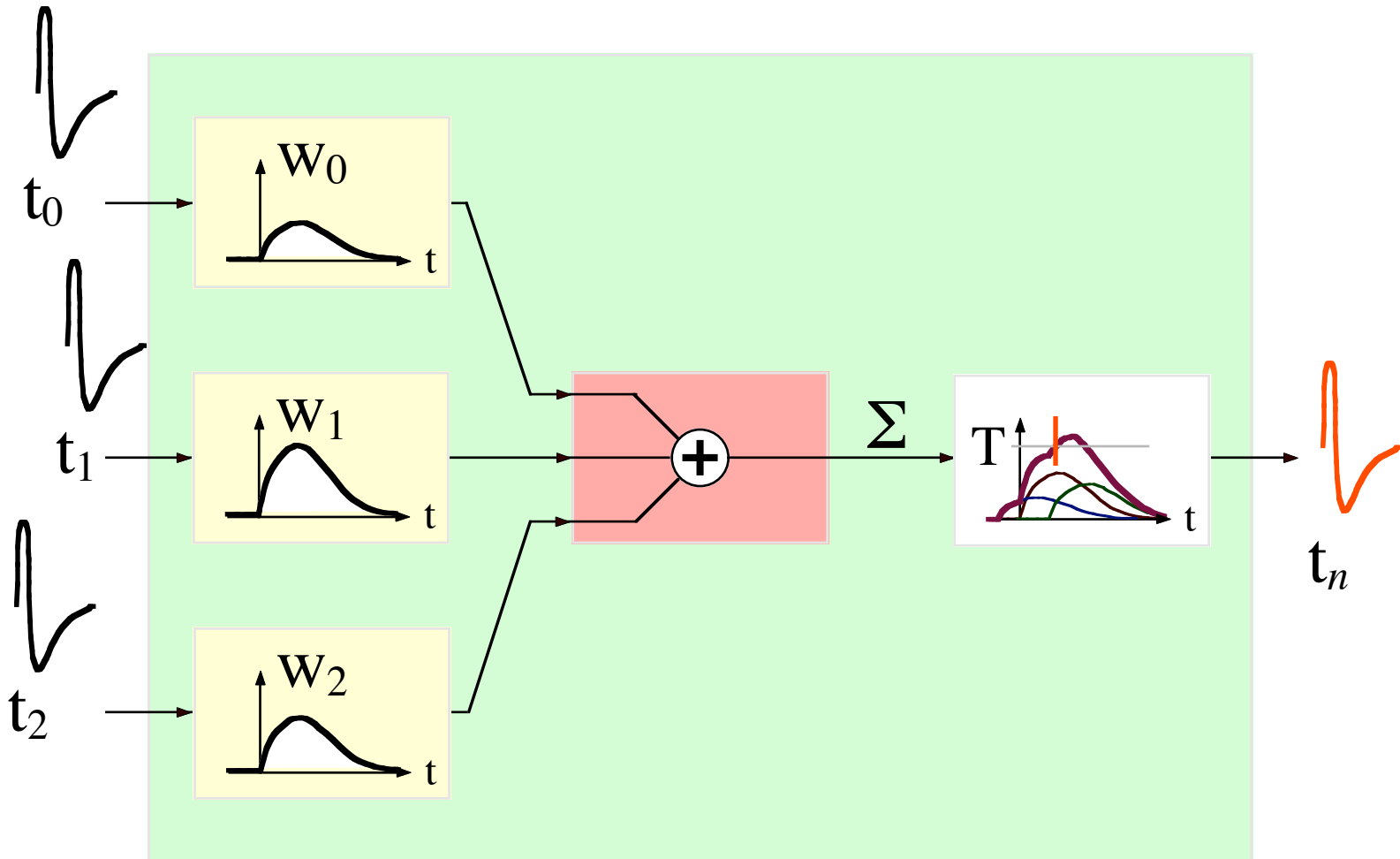

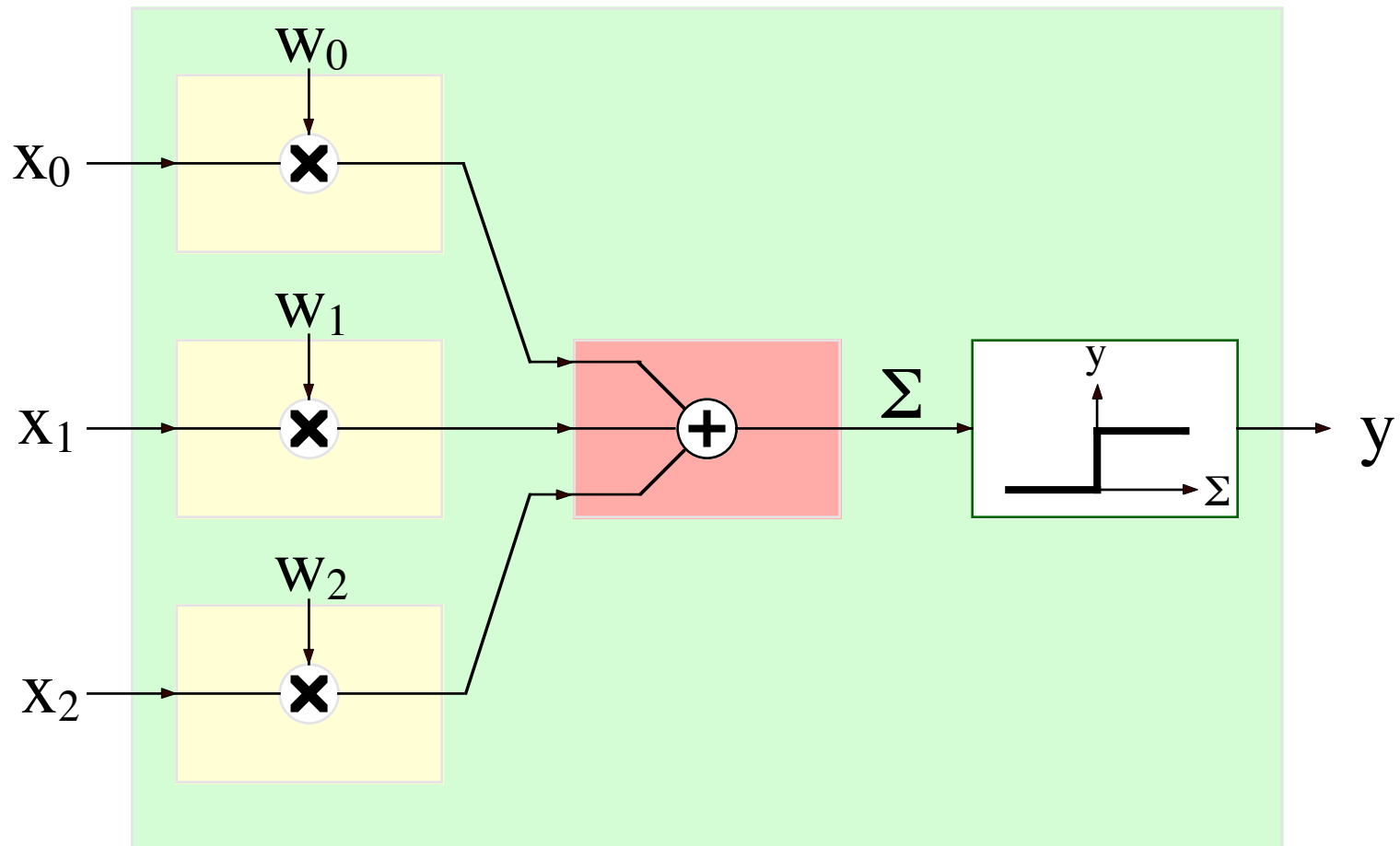

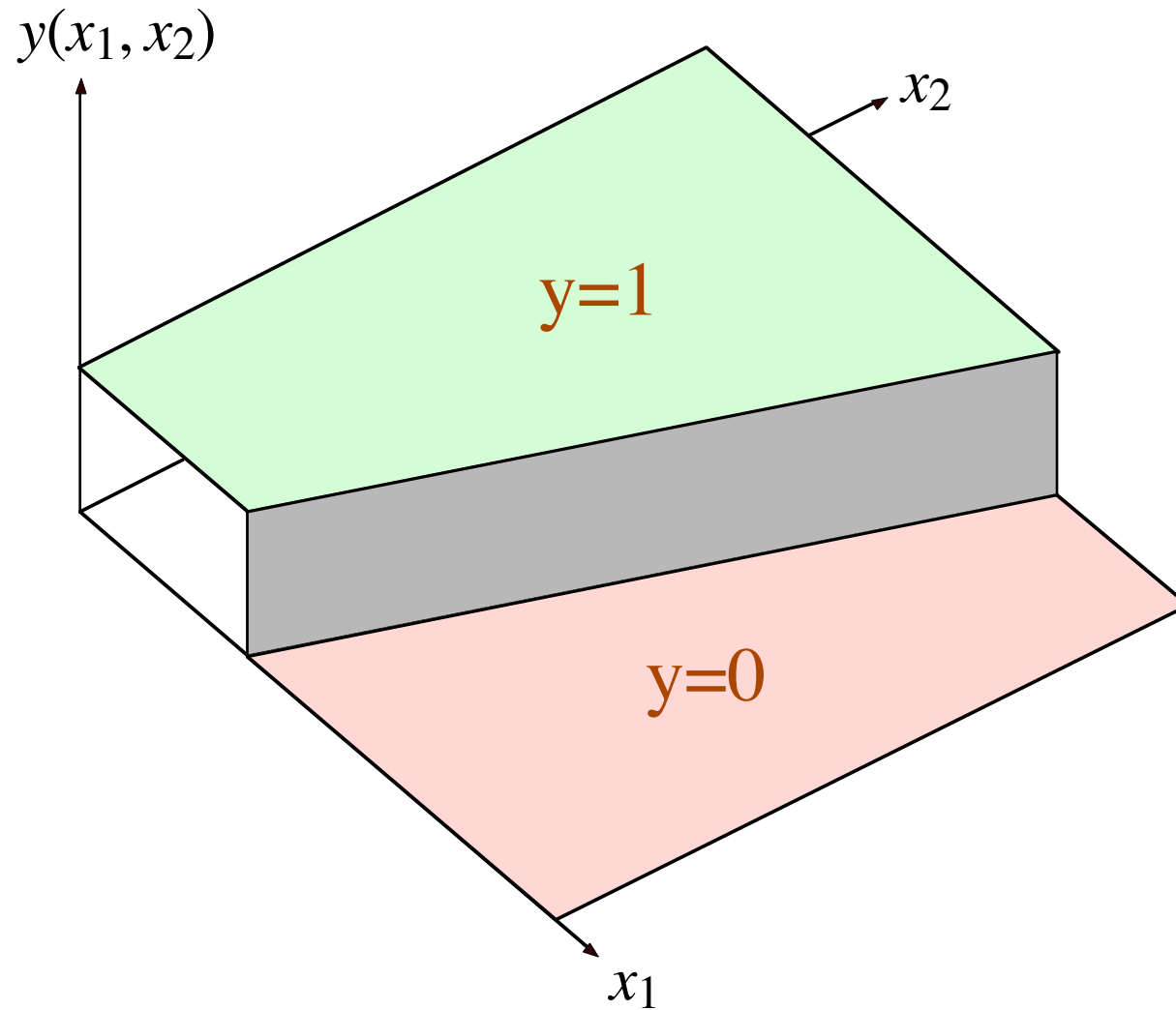

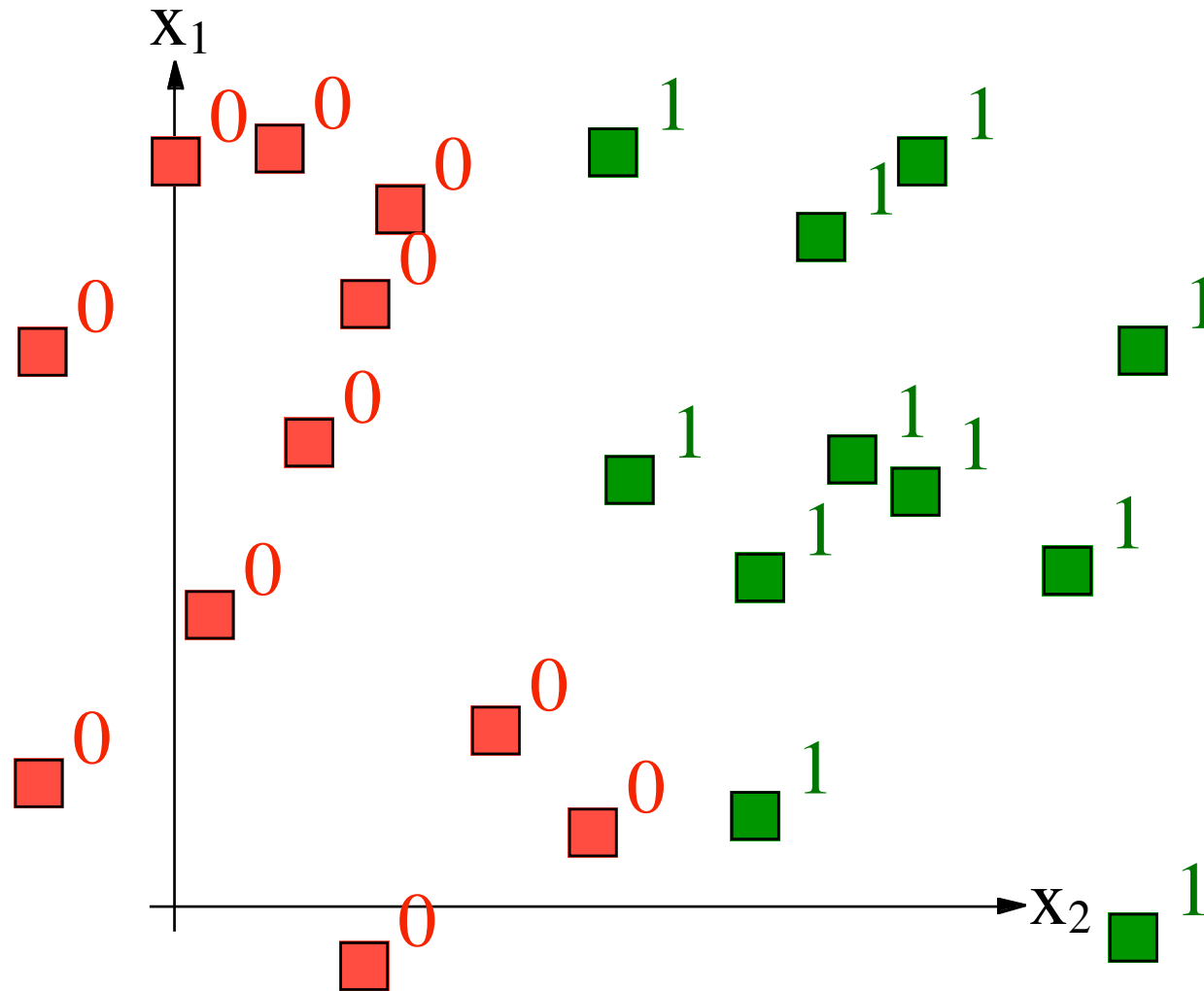

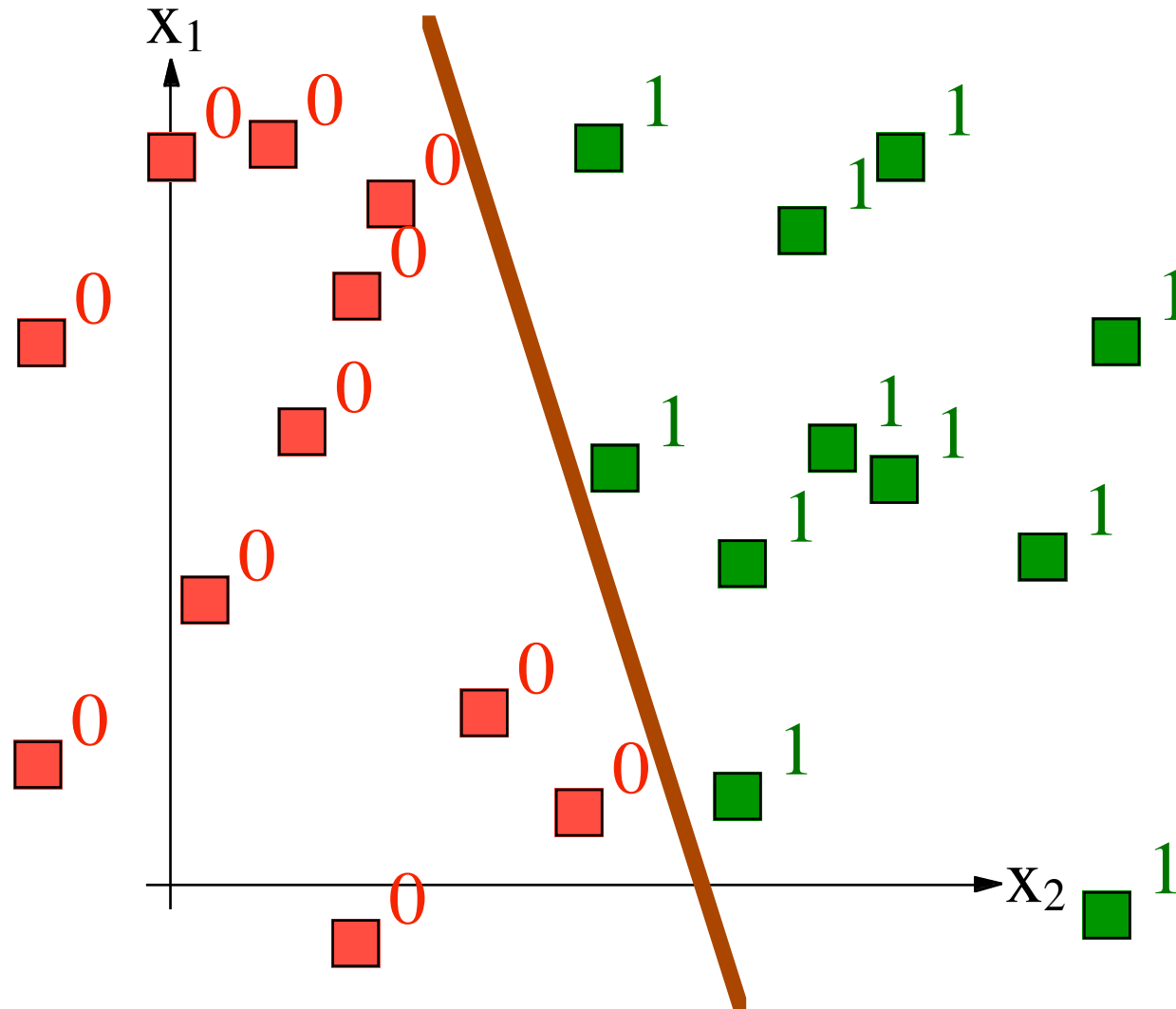

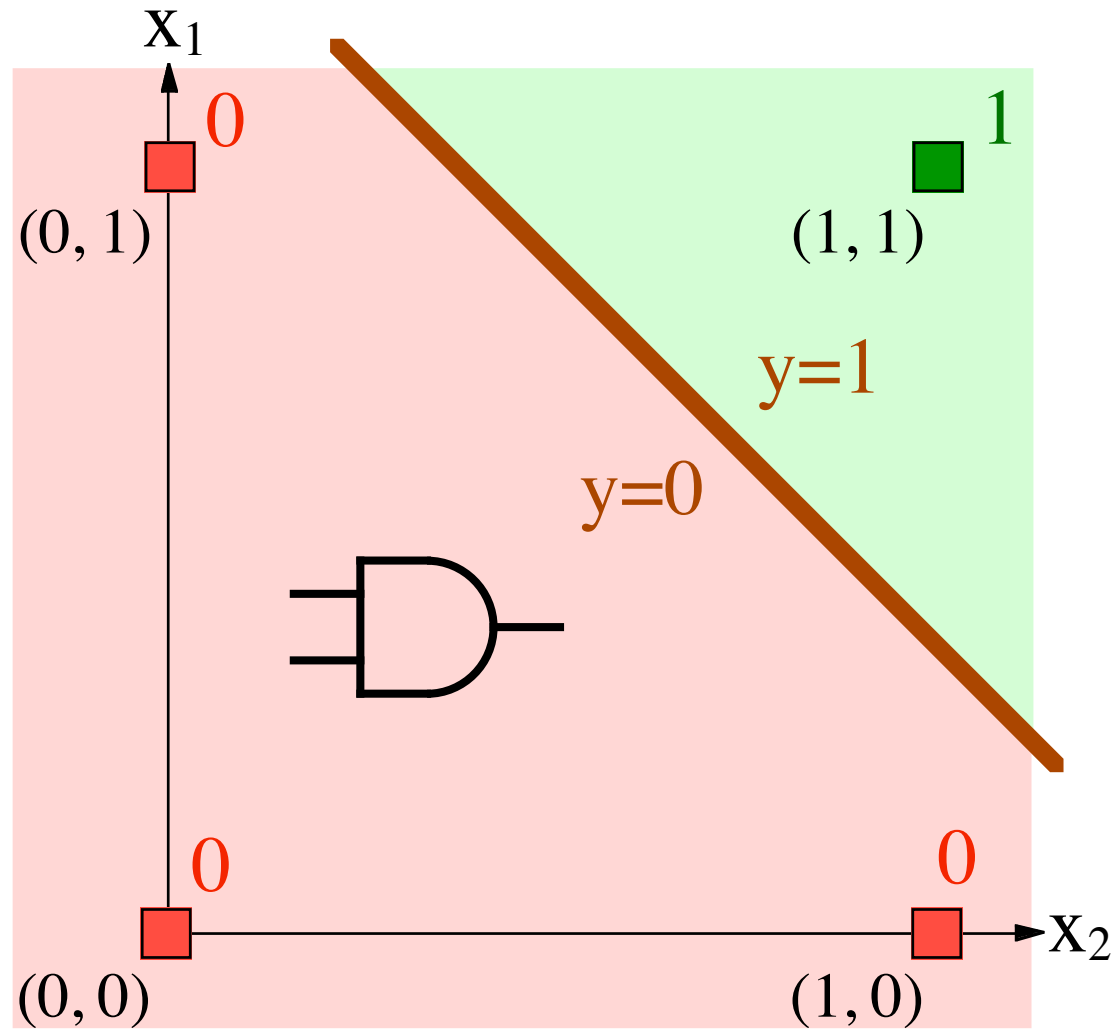

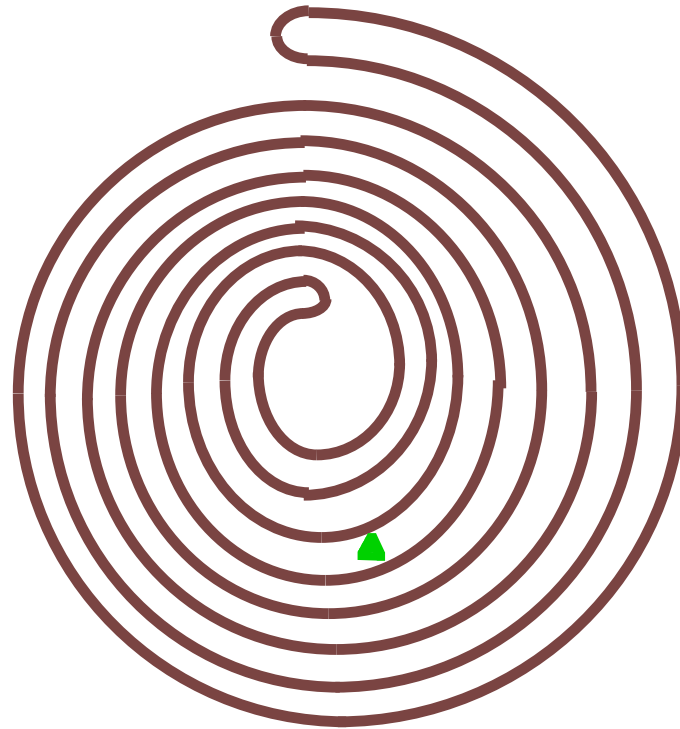

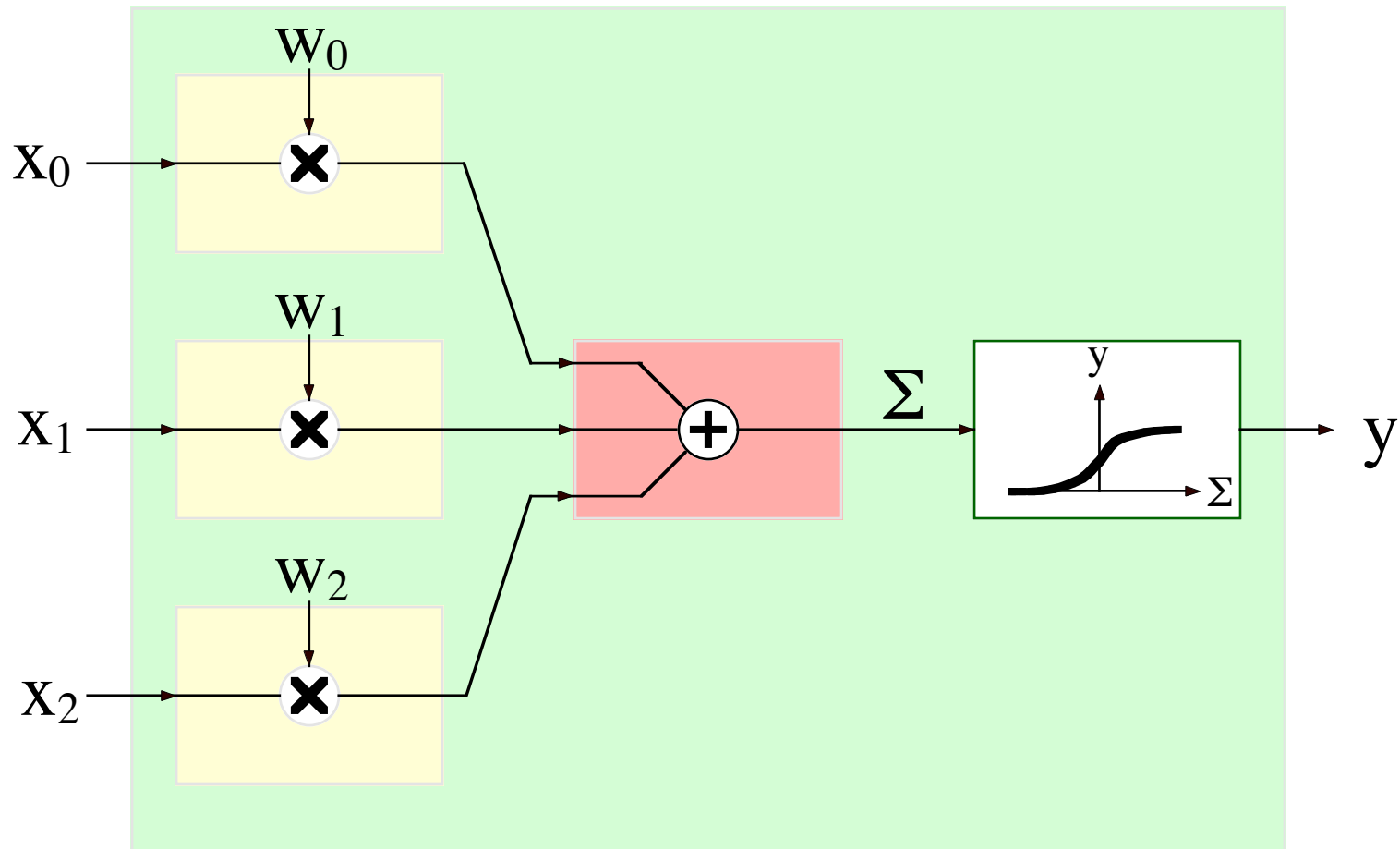

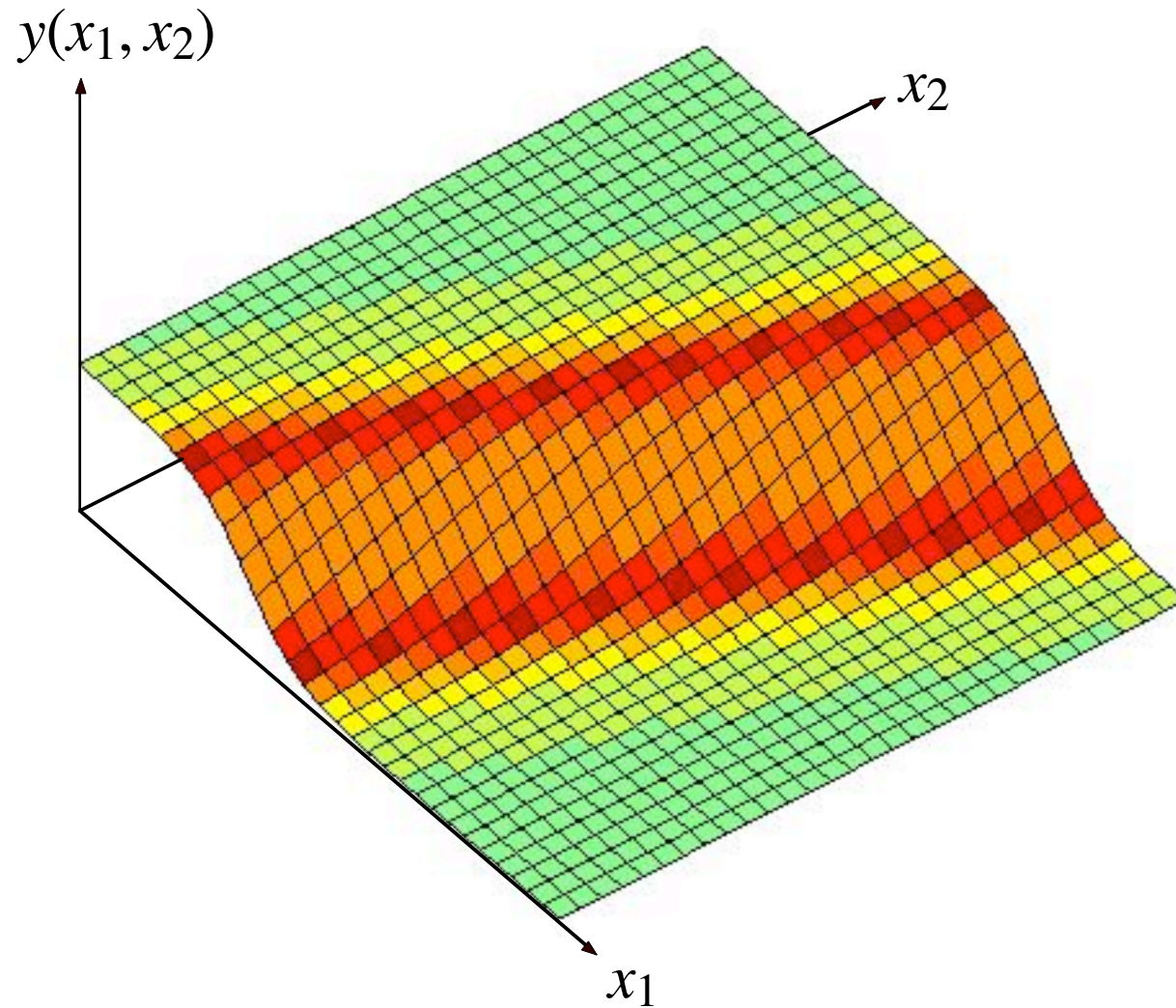

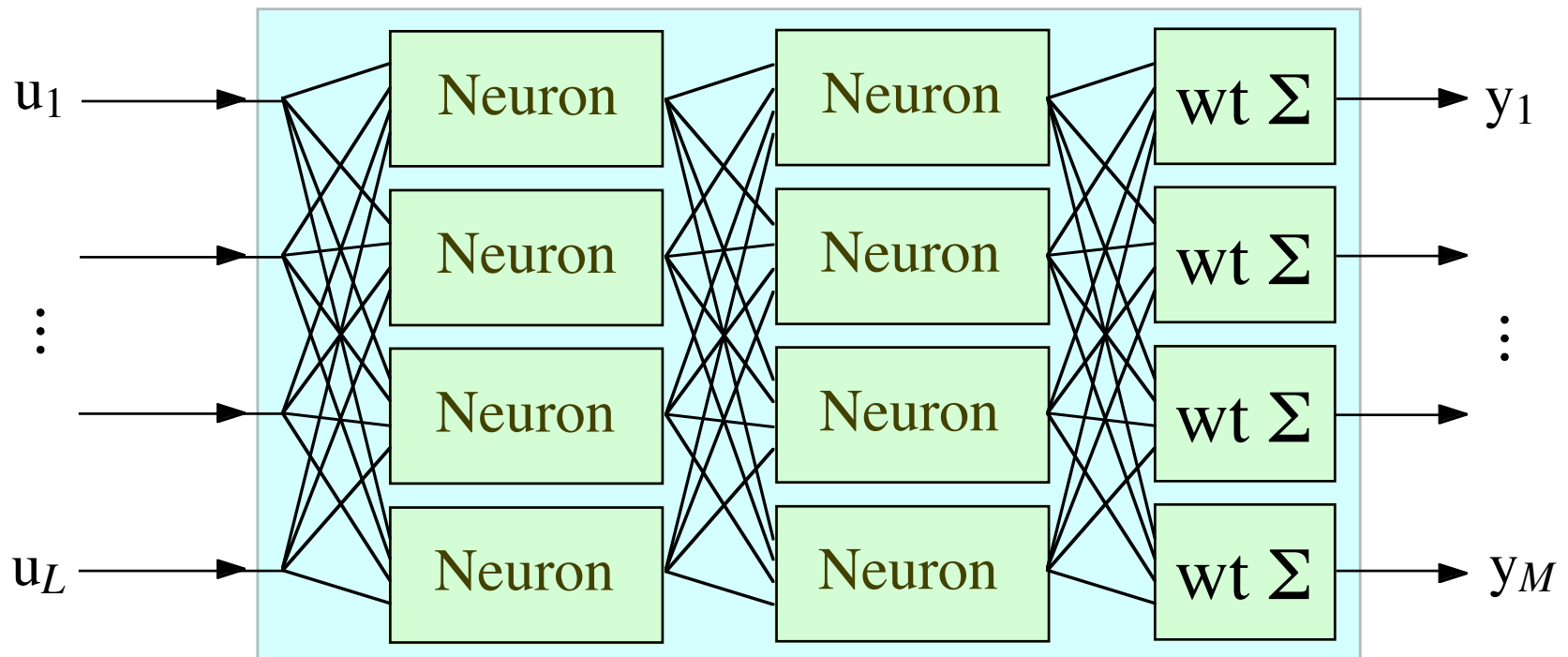

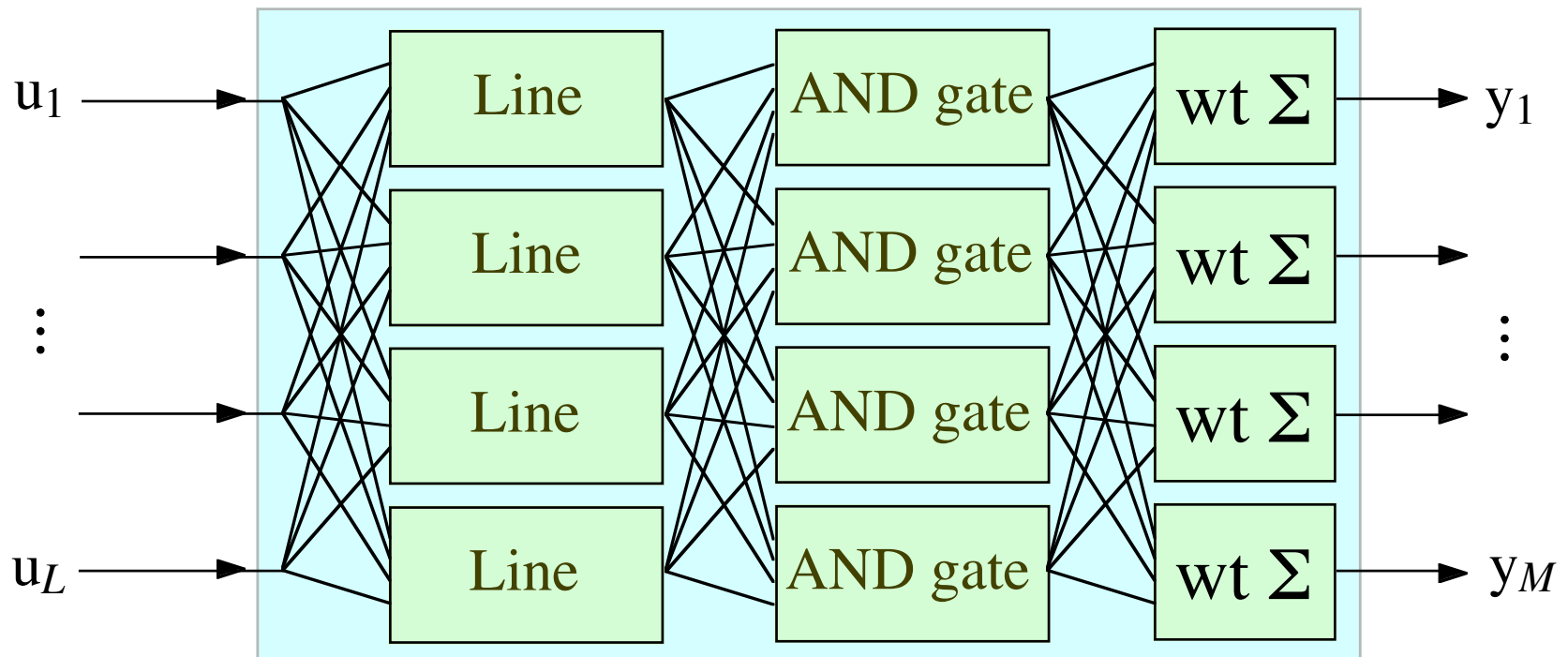

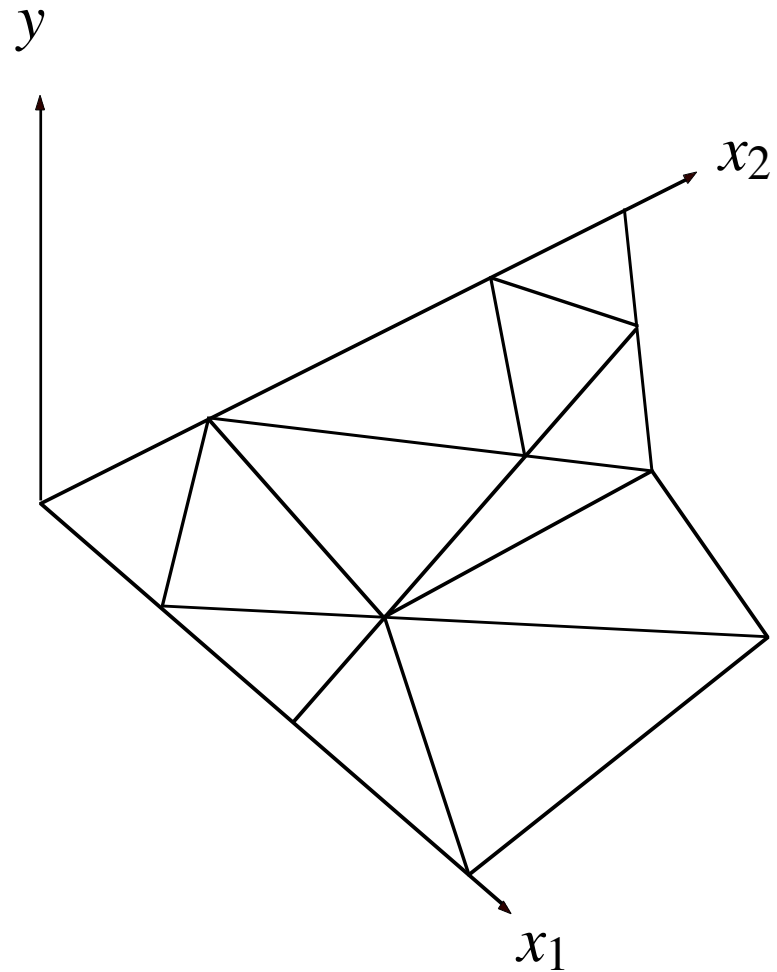

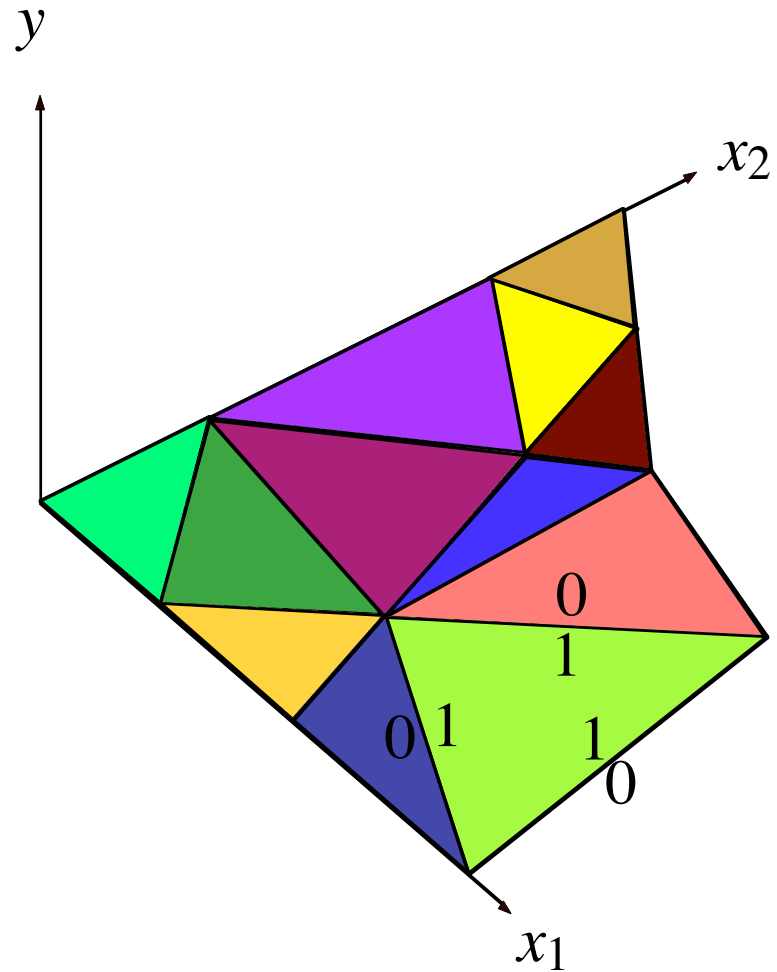

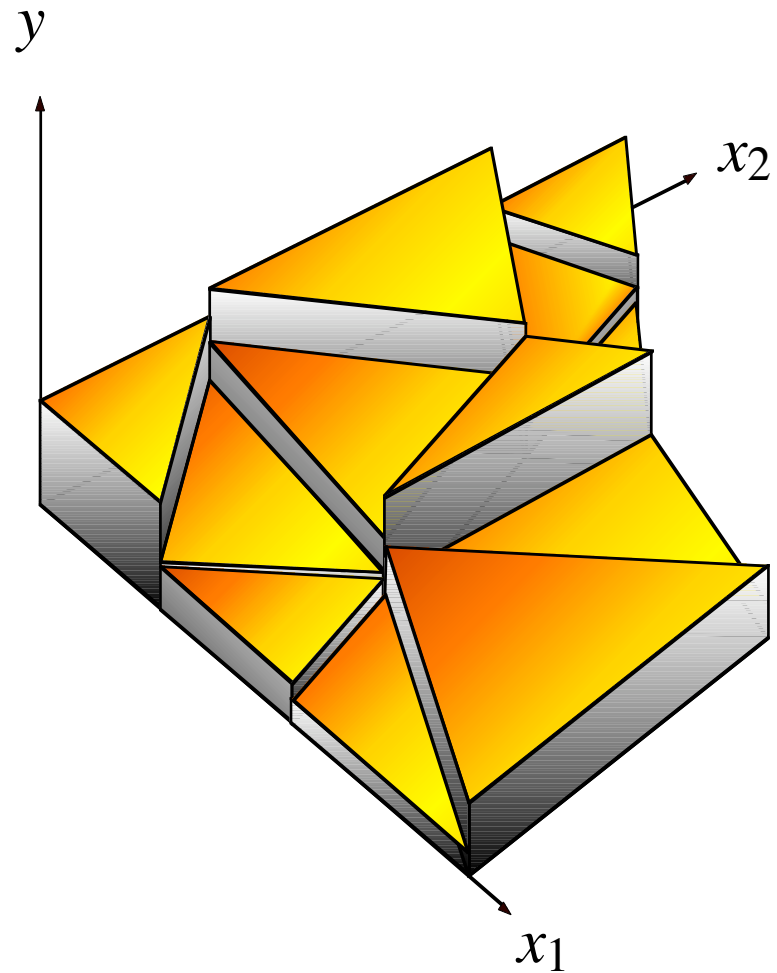

Interpolation

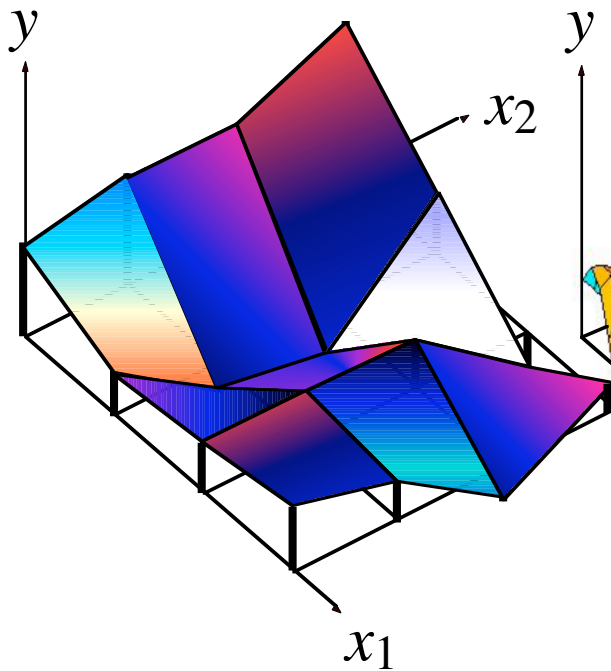

Fourier Series

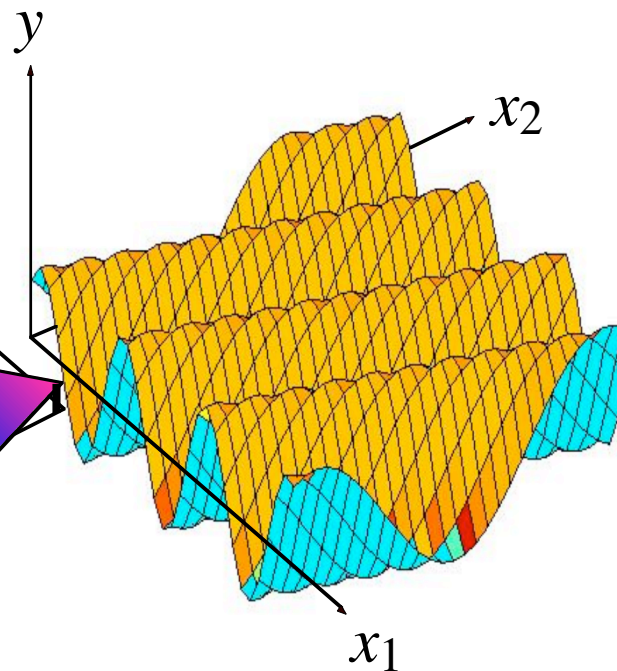

Triangulation

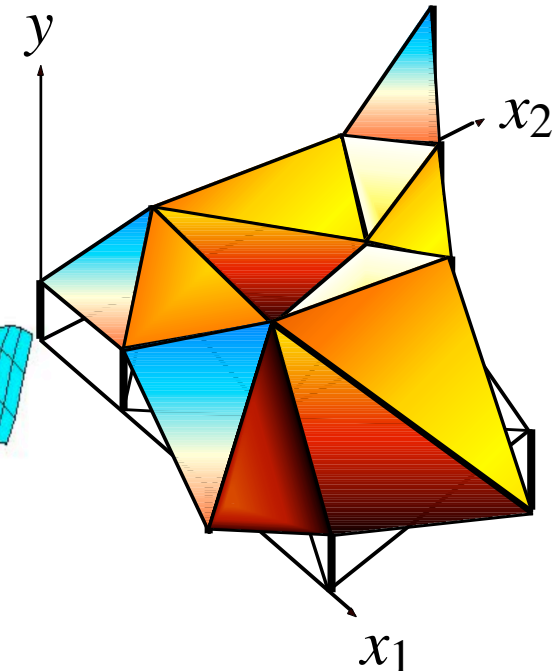

Learning

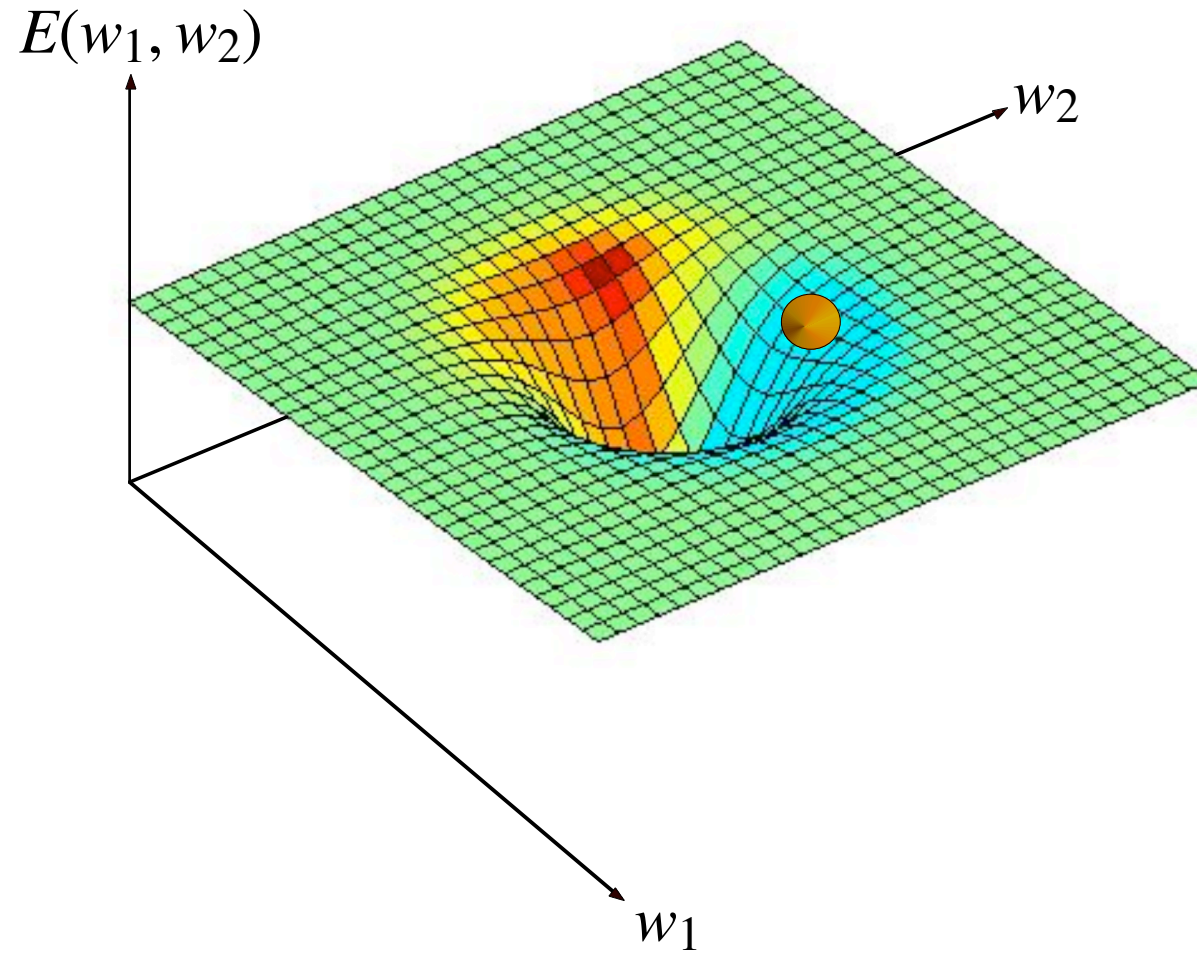

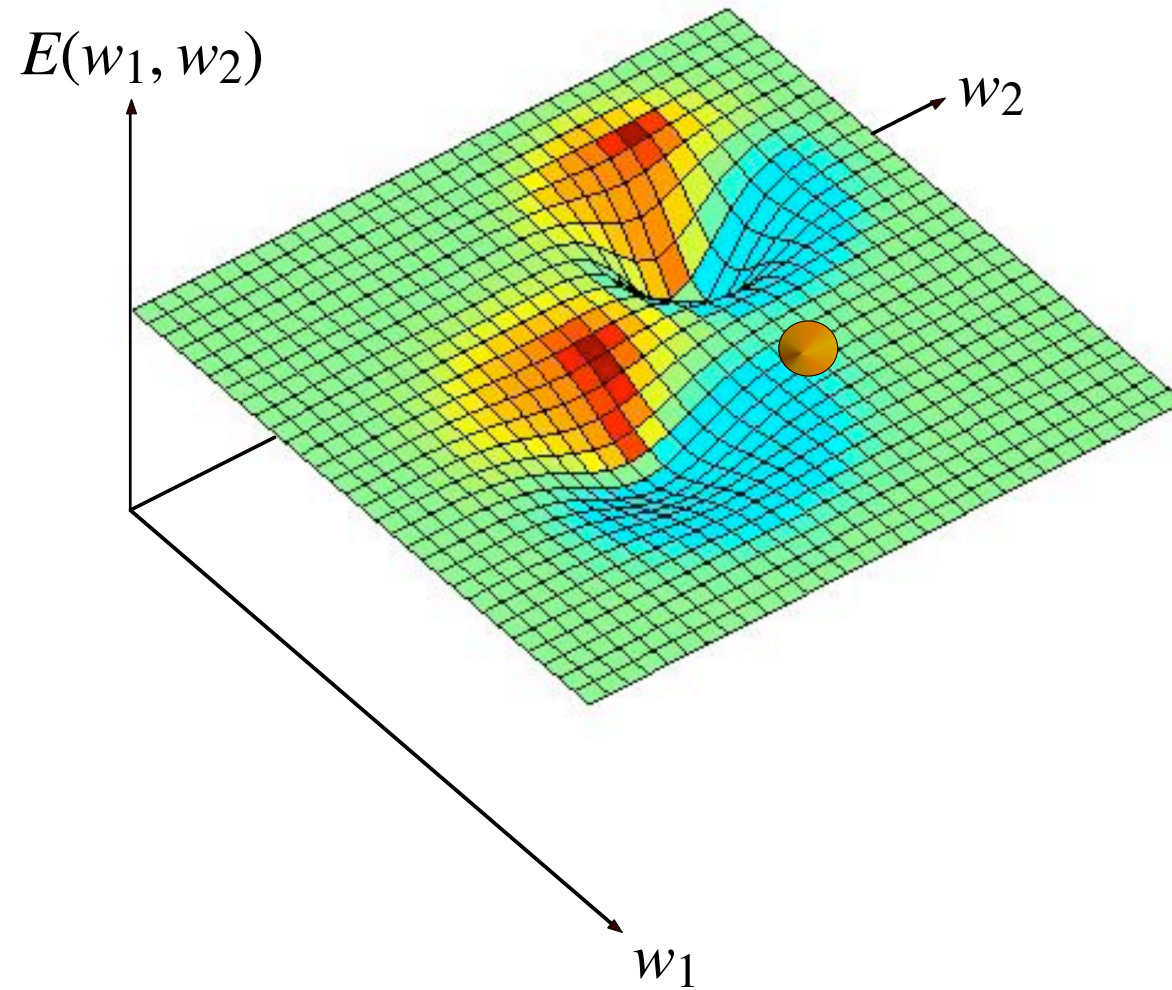

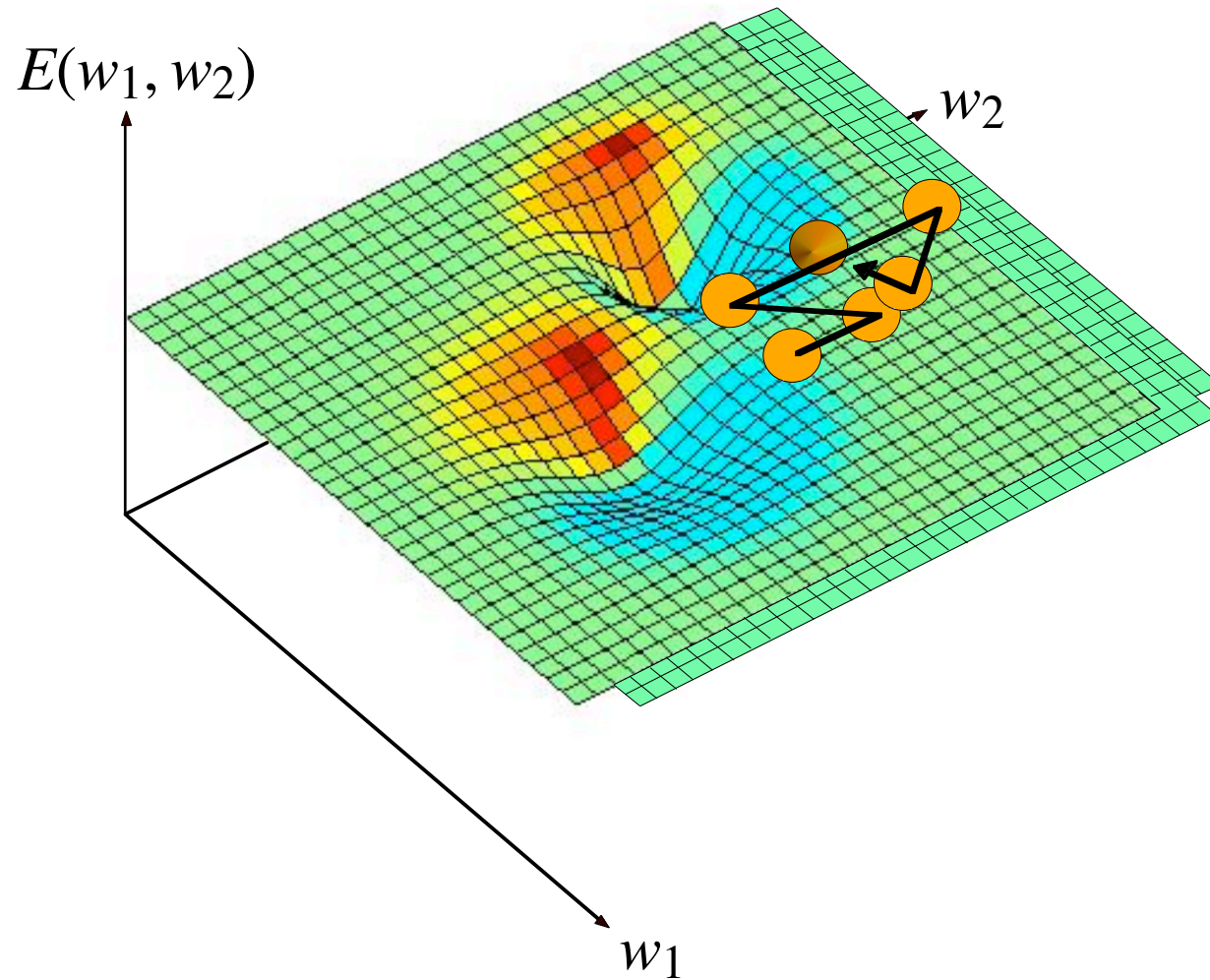

Dynamic Networks

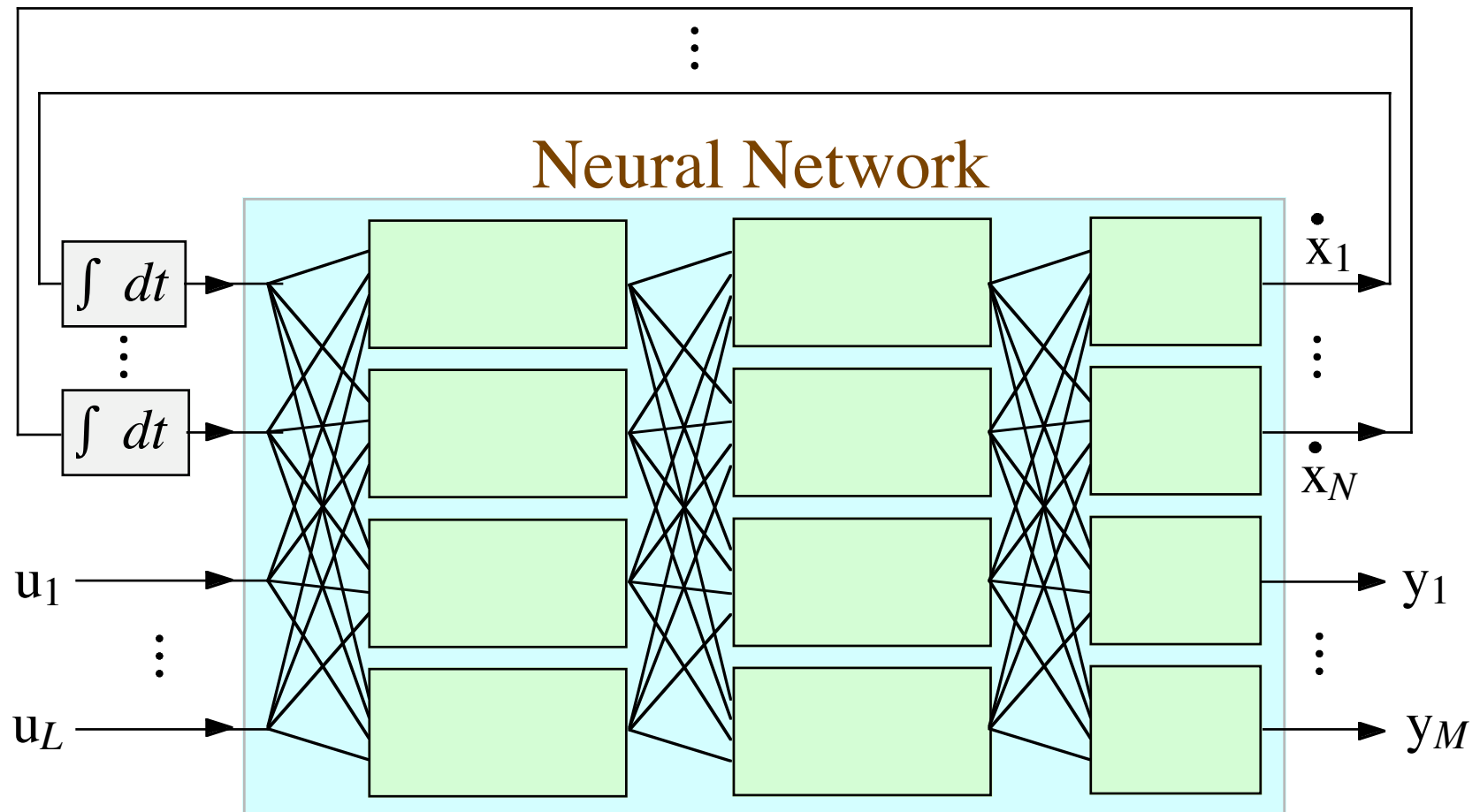

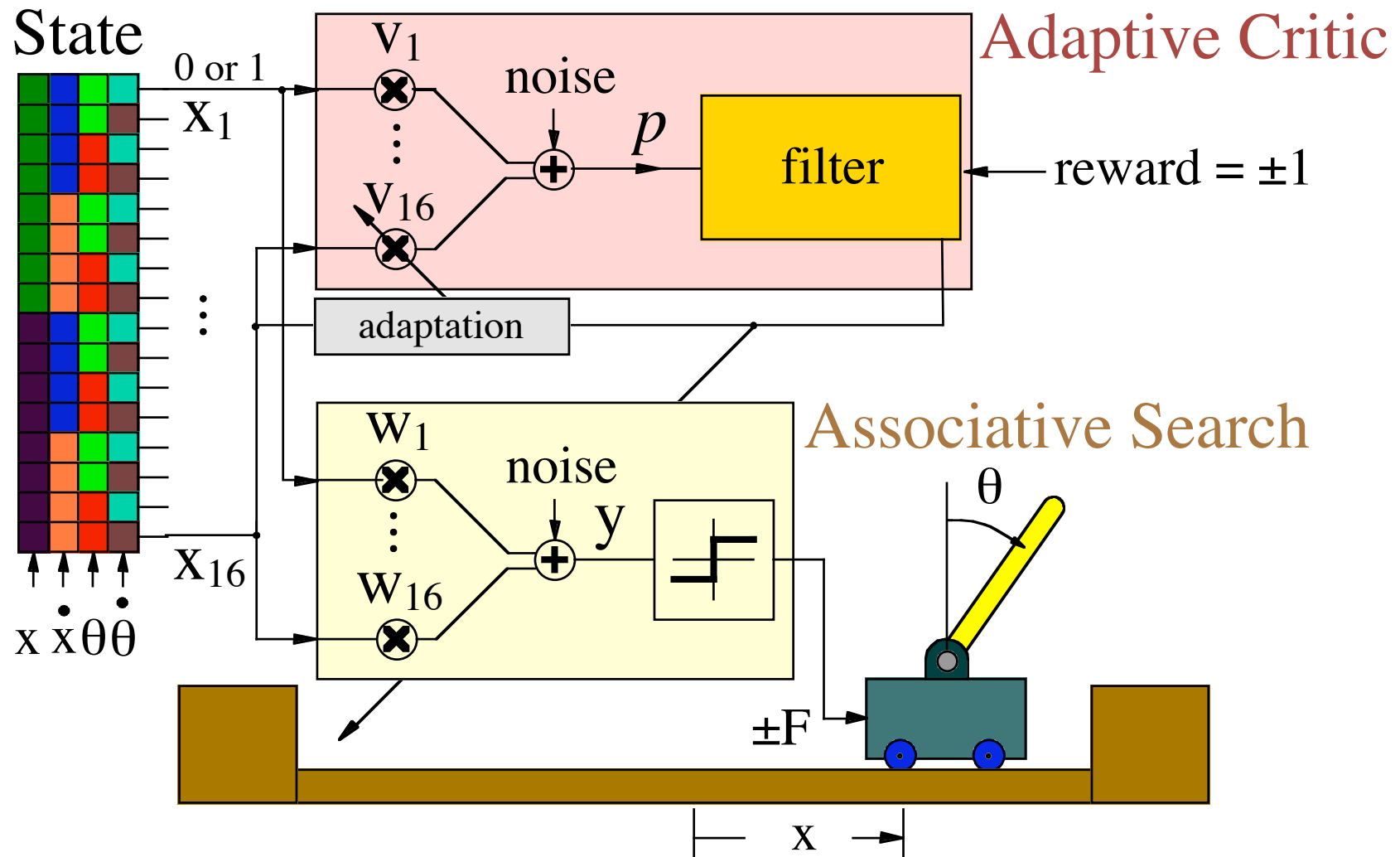

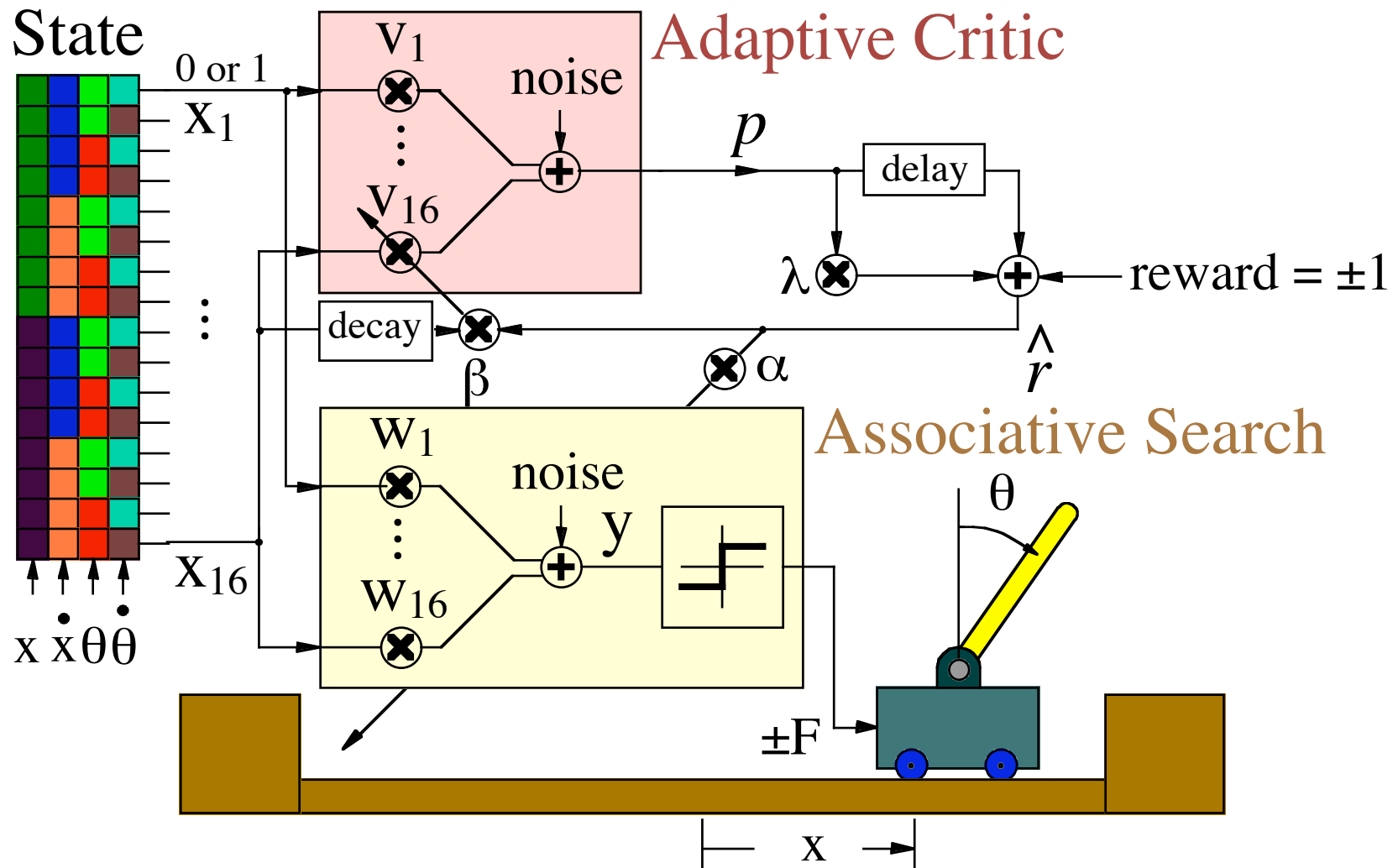

Pulsed Networks

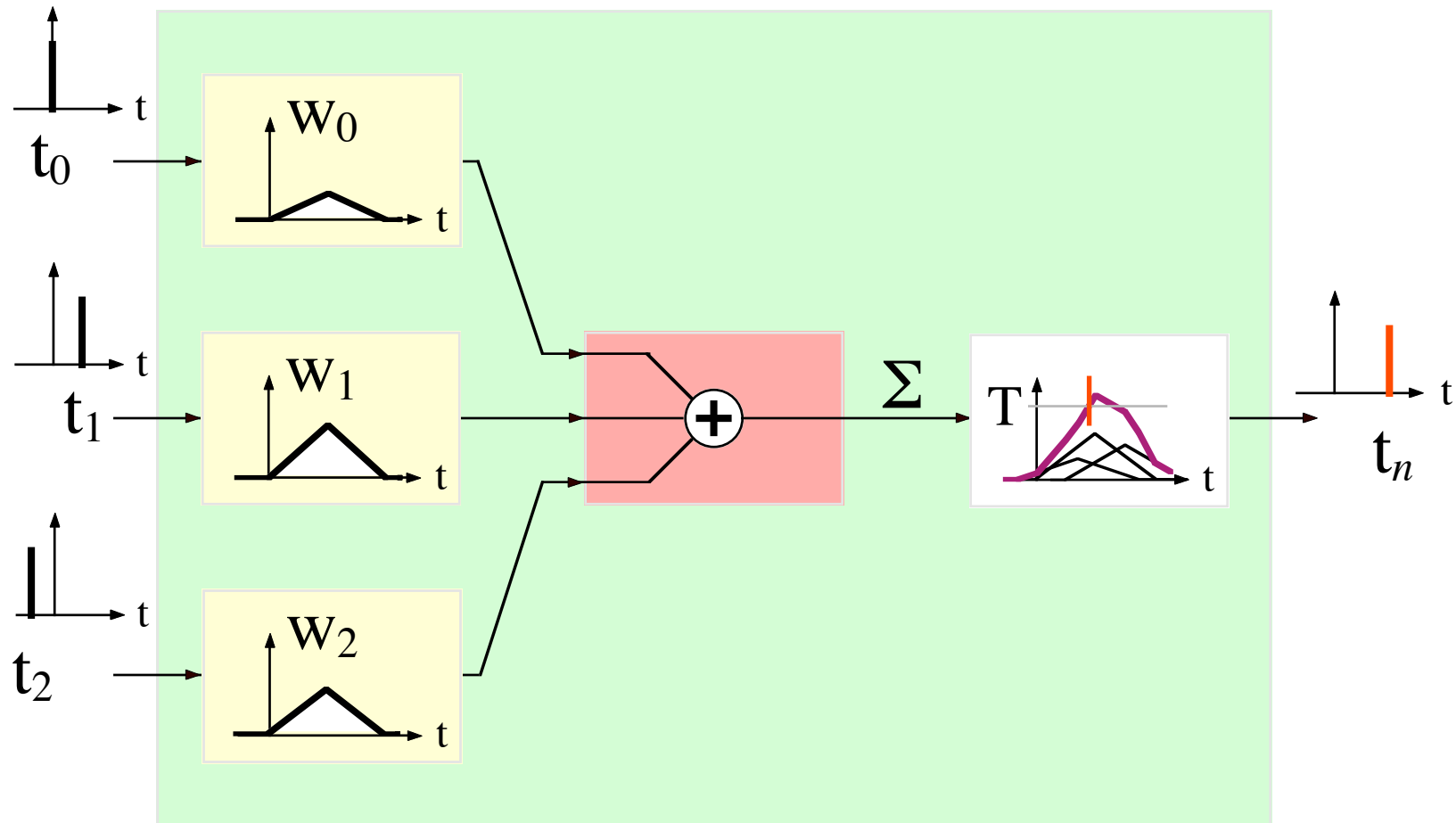

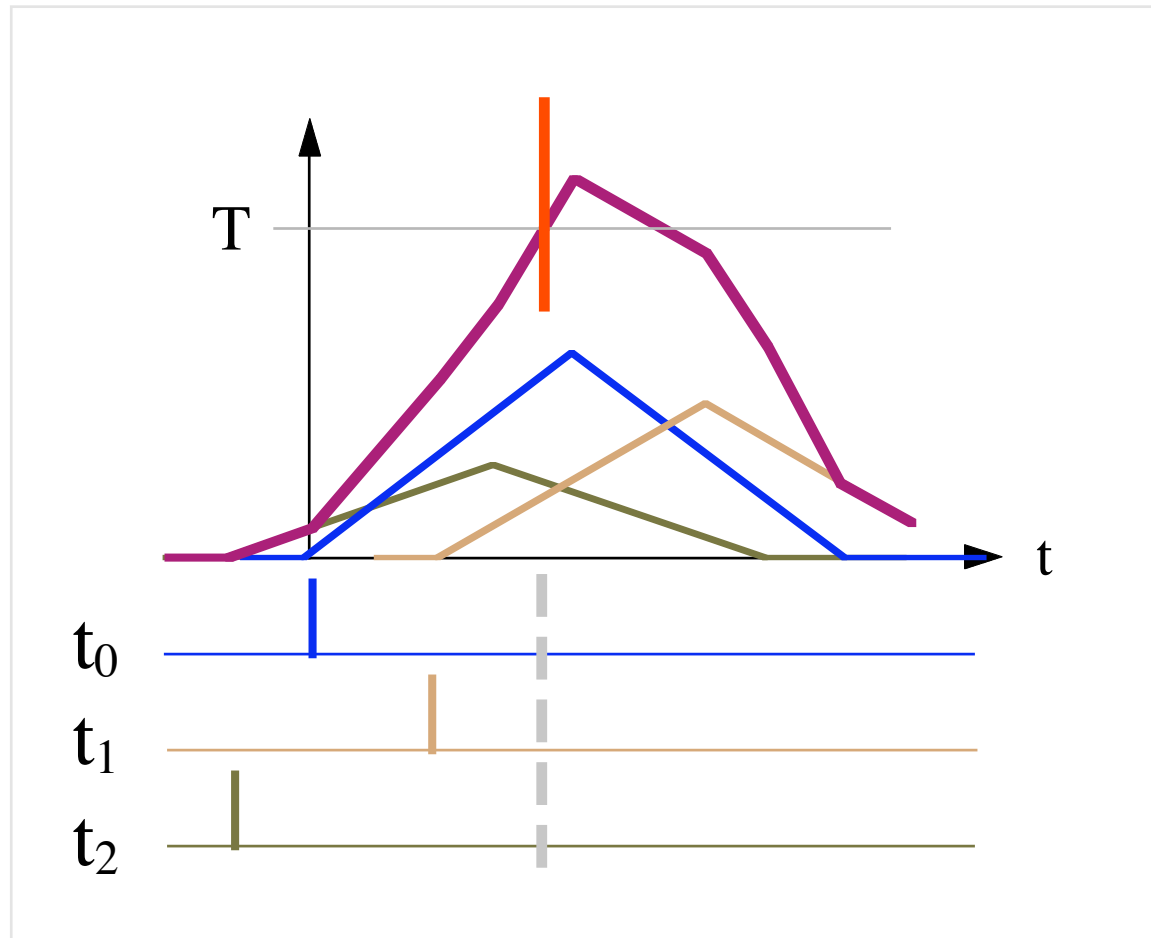

Perceptron

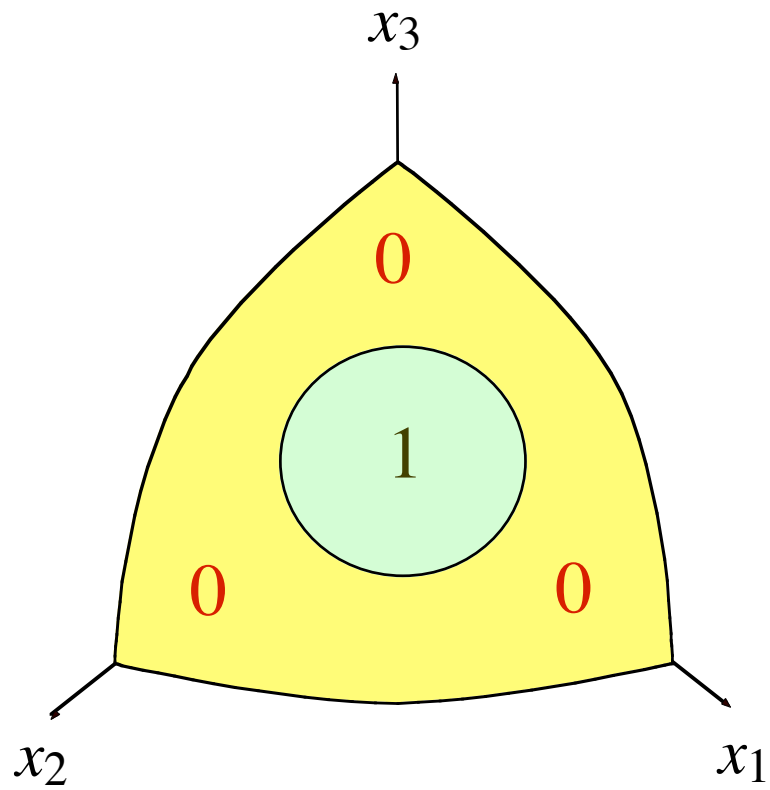

Pulsed Neuron

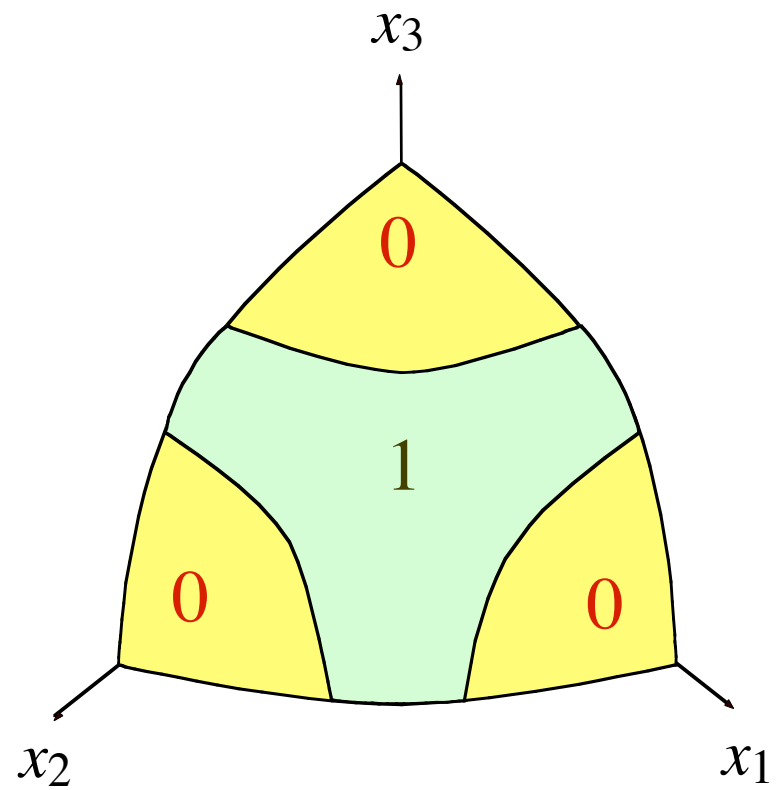

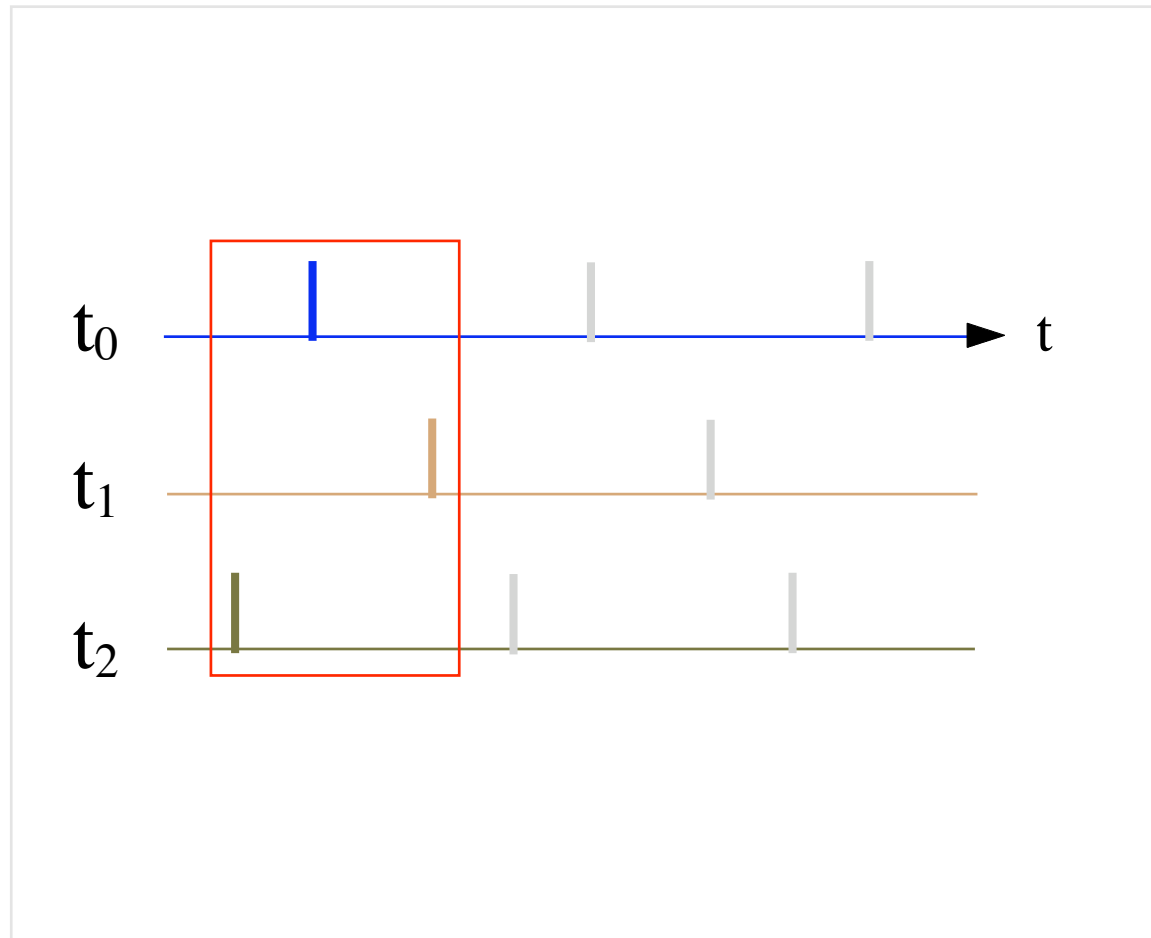

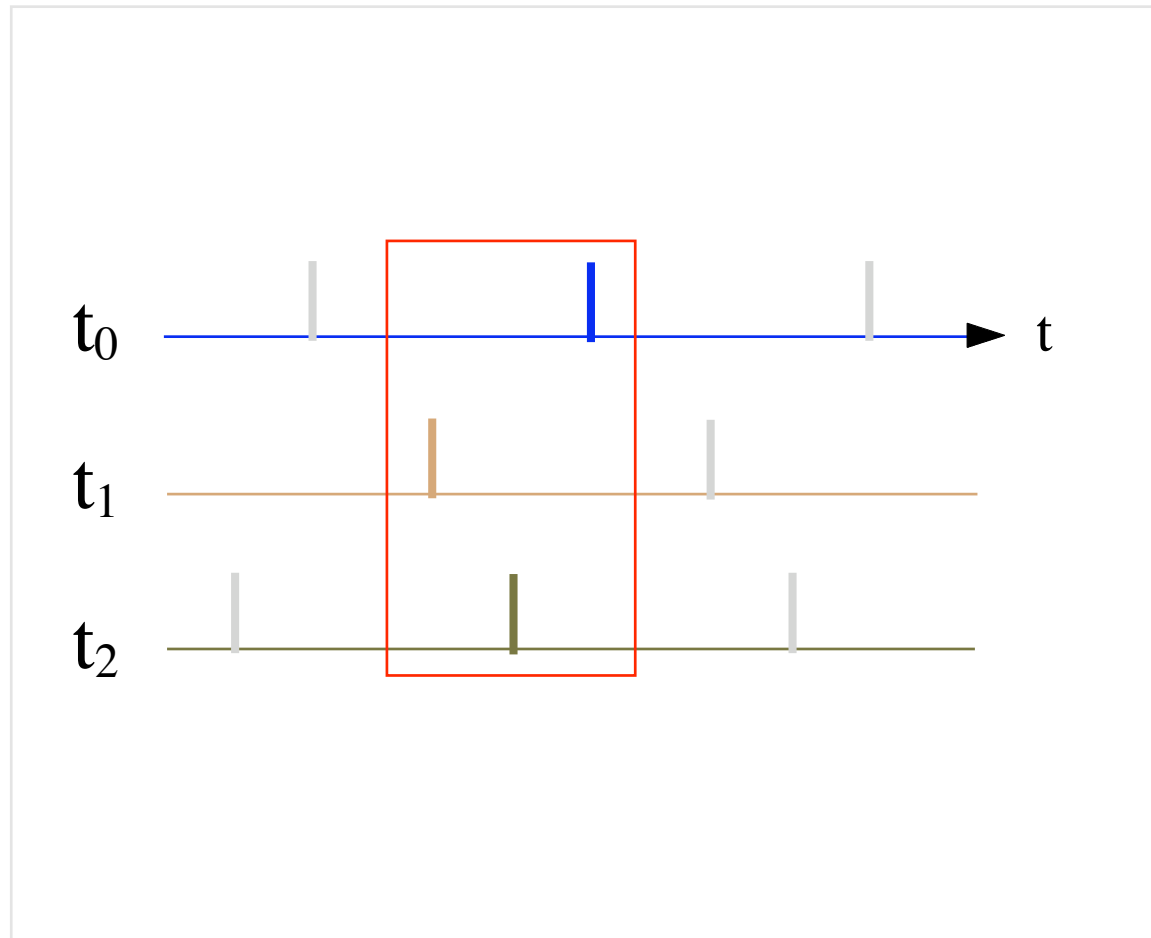

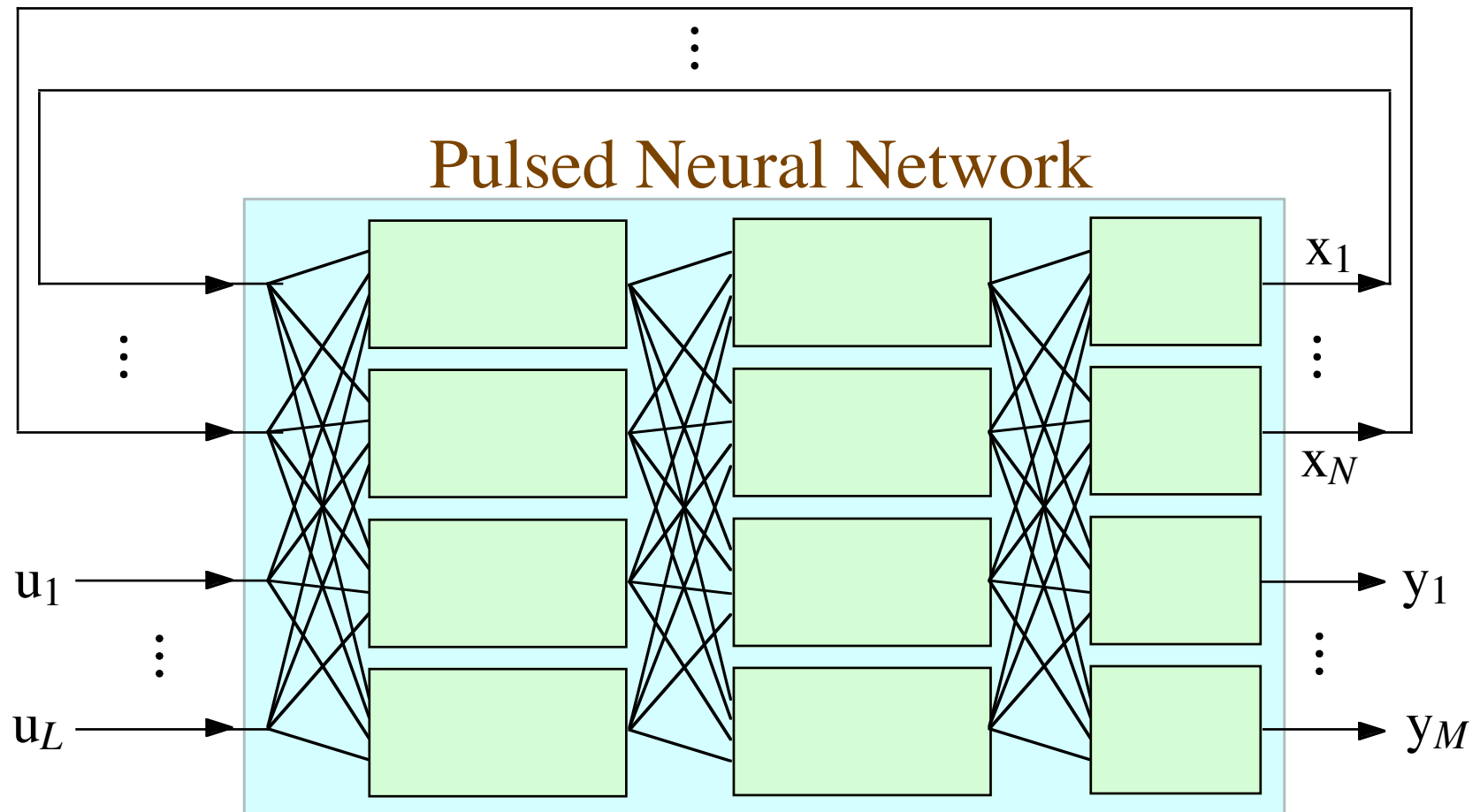

Applications

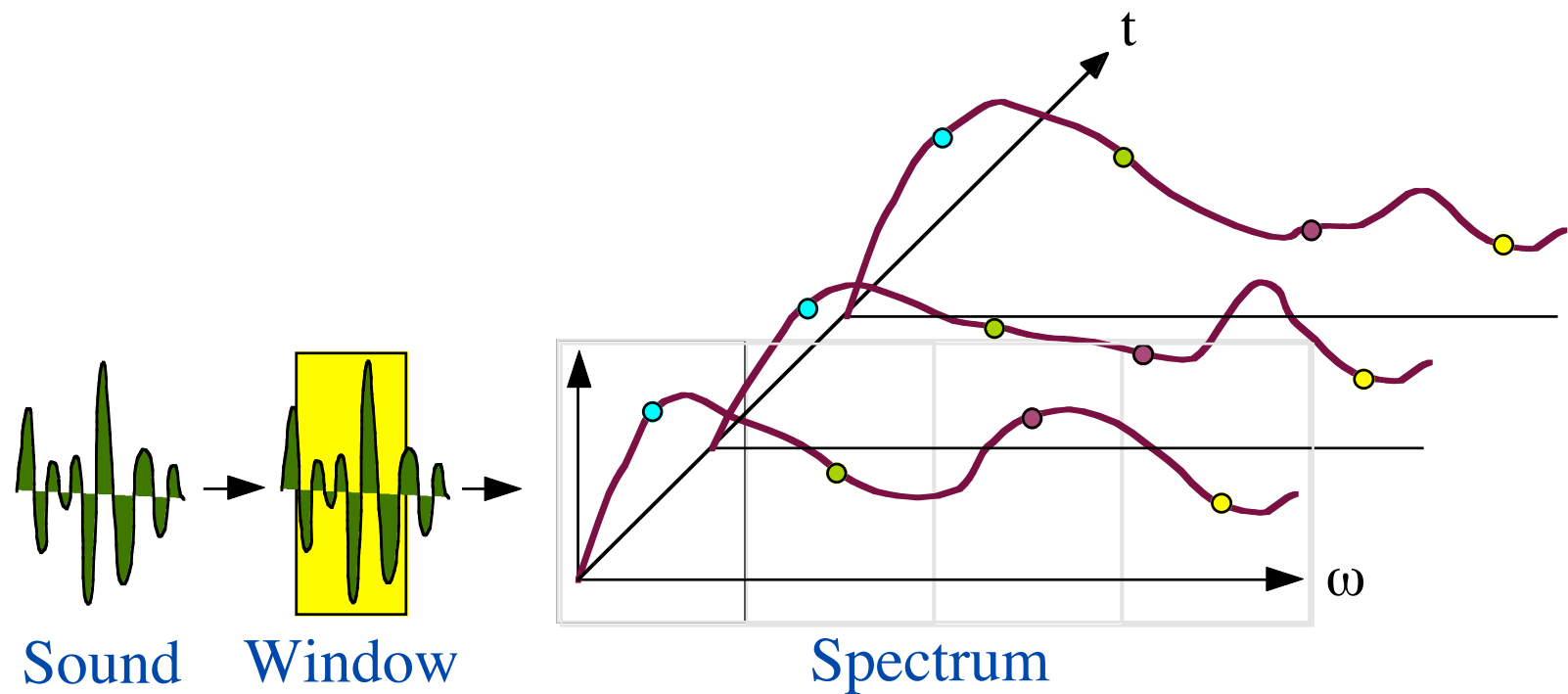

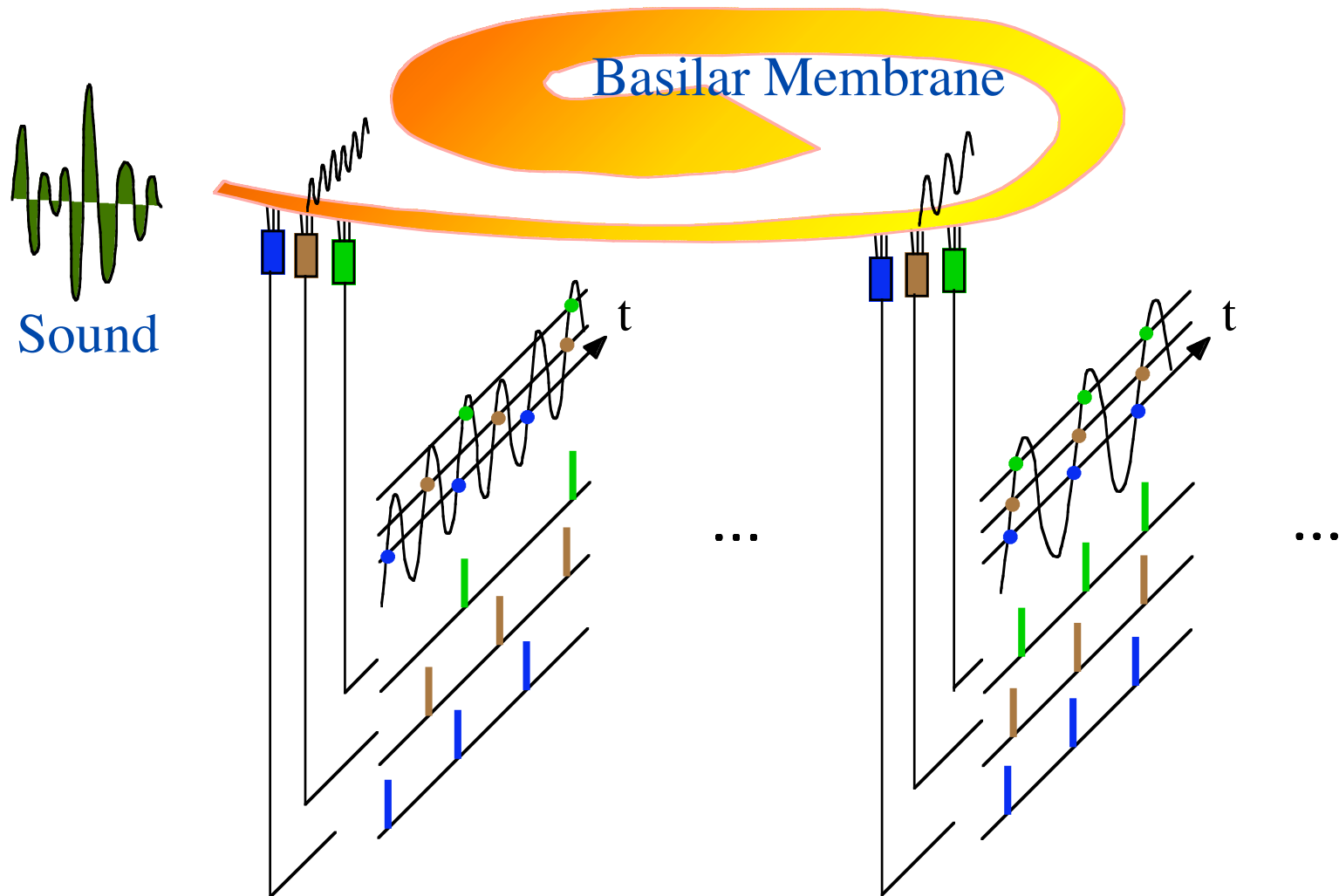

Mathematically describe pattern processing

Devise pattern-learning algorithms

Build circuits

