

Project #1 DC Power Supply

DUE: SEE SCHEDULE

CAUTION!

- **BE CAREFUL DURING THIS EXPERIMENT!**
- **HAZARDOUS VOLTAGES WILL BE PRESENT WHEN YOU PERFORM YOUR MEASUREMENTS!**

- ✓ Do your own work.
- ✓ Clearly present your work.
- ✓ All printouts must be readable.

ONCE THE PROJECT IS COMPLETE KEEP IT CONNECTED. DO NOT DISCONNECT THE CIRCUITS AFTER YOU GET THIS PROJECT TO WORK. THEY WILL BE USED THROUGHOUT THE REST OF THE SEMESTER.

OBJECTIVE:

- Design a dual rail, regulated, DC power supply to supply enough current to operate the microphone and speaker circuit from **Lab #2**.

REQUIREMENTS:

- Design a dual rail, any voltage, regulated, DC power supply capable of supplying enough current and voltage to operate the microphone and speaker circuit from **Lab #2**.
- The power supply is to be powered from the wall outlet.
- The supply must have a maximum voltage ripple of 1%.

BACKGROUND INFORMATION:

DC power supplies are extremely common in the world of electronics. They are used for almost every type of electronic equipment (i.e. computers, TVs, stereos, cell phones, etc.). In addition to requiring a DC voltage, most equipment requires that the voltage be well controlled or regulated.

You may approach this design any way you desire. You may attempt a simple power supply that meets the requirements above or attempt a more complex design. A block diagram of a simple power supply is shown below in **Fig.1**. The following circuit components staged together as shown in **Fig. 1** make a DC power supply:

- **Transformer** - The transformer provides the necessary voltage reduction for the DC circuit as well as isolation from the AC line.
- **Rectifier** - A full or half wave rectifier could be employed to convert the AC output from the transformer to DC.
- **Filter** - Filtering will be required to limit the voltage ripple.
- **Regulator** - An ideal regulator provides a constant voltage regardless of the load on the power supply. Your voltage regulator must provide the specified level of regulation under no-load and full-load conditions.

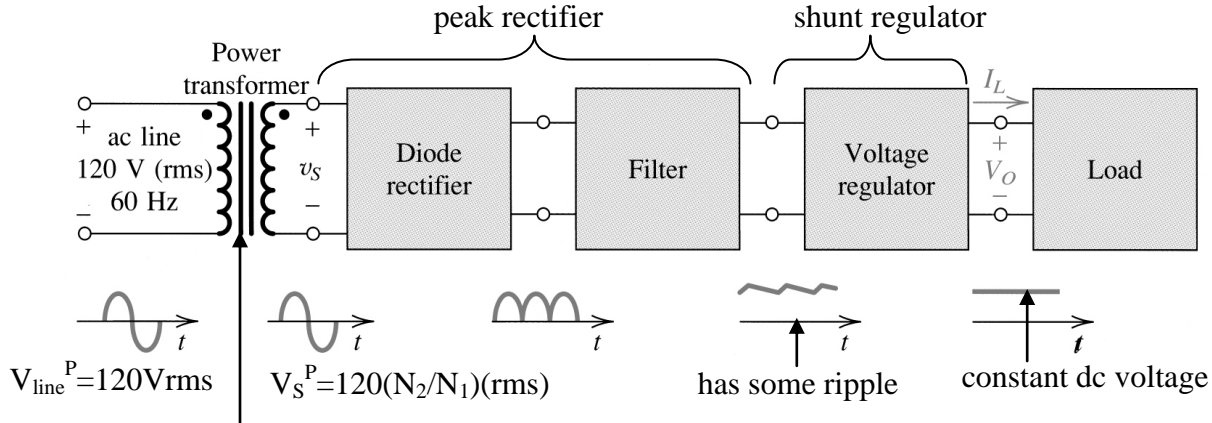

Fig. 1: Power Supply Block Diagram

Circuit Components:

- **Transformer** - A transformer that is around 25V can be checked out from the stockroom. I would suggest writing down the number of the one you work with since they are all different. Depending on how you design your power supply, a test of the voltages and currents from the transformer may need to be measured to allow the completion of the design. You can also use the nominal voltage rating and see what happens in the simulation if the transformer is less or more than you assume. The ones in the stockrooms are 25V and have a center tap. This means that if you measure across the two outer taps, it will be around 25V and 12.5V from each outer tap to the center-tap.
- **Rectifier** - The rectifier can be constructed using a silicon diode or rectifier circuits.
- **Filter** - You should require one capacitor per rail for finished circuit. Polarity of electrolytic capacitors is important!
- **Regulator** - Zener diodes and/or IC regulator chips are available from the stockroom for the regulator circuit.

- **Resistors** - Very important: note that resistors (and capacitors) only come in discrete values, with the step sizes depending on the % tolerance.

Example Schematic:

Below is an example schematic which can be used as a starting point.

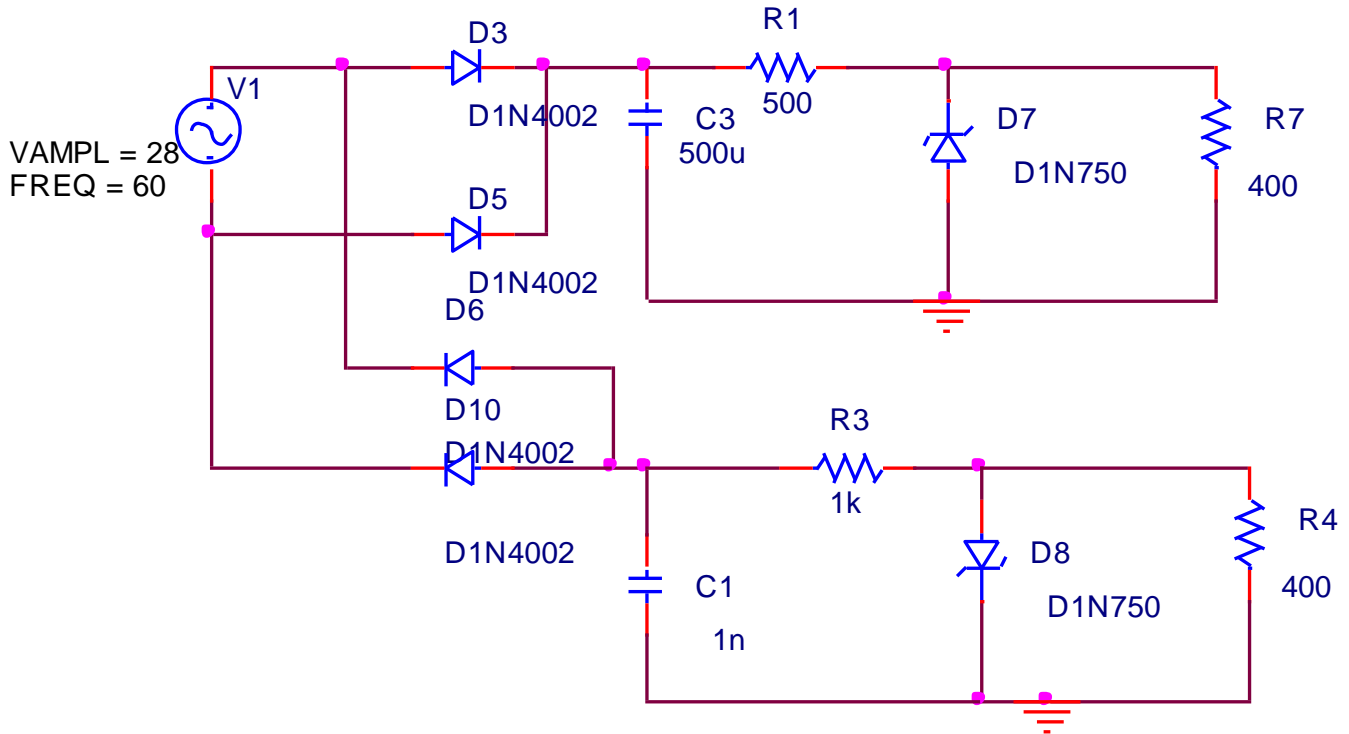

The VAMPL=28 is the voltage from measuring the transformer across its two outer taps (Vtransformer). R4 and R7 are a lumped up equivalent resistance that models the complete op amp/speaker circuit. The current value that goes through R4 and R7 is read directly from the bench power supplies that are connected to your op amp complete circuit from lab #2. Once this value is measured in the lab, R4 and R7 are found by

$$R4 = -V_{powersupply} / I_{measured_from_negative_supply}$$

$$R7 = +V_{powersupply} / I_{measured_from_positive_supply}$$

General Guidelines:

Your course textbook will serve as a good starting point for the design process. Start with the schematic given above. If you want, check out a transformer from the stockroom and measure it to get an exact value. This value will be used as your voltage supply in the simulation. If you don't measure the transformer, make sure to perform simulations that are above and below the rating to see what effect it has on the circuit.

WARNING:

- **CONNECT THE OSCILLOSCOPE ONLY TO THE SECONDARY!**
- **NEVER CONNECT THE SCOPE TO THE PRIMARY!**
- **THE NEGATIVE LEAD ON THE SCOPE PROBE IS GROUND.**
- **IF YOU CONNECT THIS LEAD TO THE PRIMARY, YOU WILL CAUSE 120 VRMS AT 20 AMPS TO SHORT THROUGH YOUR PROBE TO GROUND!**

The transformer is modeled as a voltage sinusoid in the schematic. Therefore, you would change its amplitude based on your measurements of the transformer you plan to use for the project. Make sure to note which transformer you are checking out from the stockroom since they are all very different from each other. Use Section 3.4 and 3.5 to help modify the values in the schematic.

Note: There is a tradeoff between current (Eq. 3.92) for the power supply and ripple voltage (Eq. 3.83). You need to make sure that there is enough current going to the complete speaker microphone circuit.

100 pts Project #1 Simulation: (Hand in to homework locker by due date)

100 pts PSPICE:

- 20 pts 1. Printout of schematic with the values modified so that it is working correctly.
- 20 pts 2. Plots of V_o (both rails): (include annotations).
- 20 pts 3. Plots of current to the load (both rails).
- 20 pts 4. Plot of voltage ripple (both rails). (This is seen by zooming in on the graph)
- 4 pts 5. Power dissipated through each component (to make sure that you will not “blow” up a component – make sure to check datasheets if necessary or rating values of components).
- 16 pts 6. Table: V_{omin} , V_{omax} , load current, maximum diode current. (+2 each and for both rails)

100 pts Project #1 Lab Work: Get this checked by your TA

25 pts NOTEBOOK:

- 5 pts 1. Check that their lab notebook is organized.
- 5 pts 2. Description of the project.
- 5 pts 3. Description of the design work.
- 10 pts 4. Design Work:
 - 3 pt Schematic of the circuit (PSpice printout or drawn out by hand).
 - 4 pts All hand calculations
 - 3 pts Comparison of PSpice simulation versus measured

75 pts PROTOTYPE:

- 35 pts 1. Dual power rails
 - Some of the measurements may include: curve tracer volt-ampere characteristics of both diode devices, load current, load voltage, voltage ripple, voltage regulation, component power dissipation, component voltages and currents. This is not a complete list. You must decide which

measurements are relevant to your design and important to a potential user of your power supply. In many cases it is necessary to record AC waveforms; measurement with a multi-meter is not sufficient (use the oscilloscope).

17 pts 2. Top rail within voltage ripple of 1%

17 pts 3. Bottom rail within voltage ripple of 1%

6 pts 4. Power

Record the power dissipation in the various components. Is this a significant factor? How would this affect the long-term operation of the circuit?