



Abstract-You will add a differential amplifier circuit to your pre-amp circuits to create an electromyogram circuit. After designing, constructing, and testing the circuit, you will connect electrodes to your biceps muscle and measure the small voltages generated by the activity of neurons terminating on muscle fibers. By recording these signals on an oscilloscope, you will create electromyograms that you will analyze to determine the rate of neural activity associated with lifting various weights.

I. PREPARATION

For Lab 1b, which will last about three weeks, you will need the additional parts listed in Table I, (in addition to the parts from Lab 1a). You may purchase these parts from the stockroom next to the lab or purchase them elsewhere.

TABLE I
PARTS LIST FOR LAB 1B

Item	Qty	Description
1	4	Resistors (values determined during lab)
2	1	LF353 Operational Amplifier
3	1	10 Ω Resistor
4	1	1 k Ω Resistor
5	1	1 M Ω Resistor
6	1	1 0.1 μ F Capacitor
7	3	Electrodes

II. LEARNING OBJECTIVES

- 1) Learn about voltage dividers and understand why pre-amps increase current drive of weak signals from electrodes.
- 2) Learn how to derive equations for op-amp circuits, such as pre-amps and differential amplifier, using Kirchhoff's and Ohm's laws.
- 3) Understand how to design a differential amplifier to meet practical constraints
- 4) Determine the relationship between neuromotor activity and force applied by a muscle

III. INTRODUCTION

In Lab 1a you built pre-amp circuits that output the same voltage as an input signal but with a higher current-drive capability. The intent is to eventually place electrodes on your biceps muscle and connect them to these pre-amps. In Lab 1b, you will add a differential amplifier to the pre-amps to complete an electromyogram (EMG) circuit that measures the tiny voltages produced by the biceps muscle and picked up by the electrodes.

EMG studies are useful for assessing the health of the neuromuscular system, since certain diseases, such as multiple sclerosis, slow down or even suppress normal nerve and muscle firing. In addition, several research groups have recently studied the possibility of using EMG signals to control artificial limbs for patients who have lost an extremity; the EMG signal would be obtained from a surviving portion of the limb and would represent the patient's central nervous system's desire to move the limb in a certain direction with a certain force.

IV. DESIGN PROJECT OVERVIEW

You will complete design and construction of an EMG circuit that receives input from two neighboring electrodes placed on the biceps of the upper arm plus a reference electrode placed on the elbow. The power in the signals picked up by the electrodes is minute. A differential amplifier is useful for amplifying the small signals. In particular, the differential amplifier magnifies the difference between the electrodes, which is equivalent to magnifying the voltage drop across the muscle.

Attaching the electrodes directly to a differential amplifier, however, would draw too much current from the electrodes, causing their voltage to drop to almost zero. Consequently, we use the pre-amps, constructed in Lab 1a, to create higher-power signals. The pre-amps can output higher current at the same voltage as the electrodes while drawing virtually zero current. The outputs of the pre-amps can then drive a differential amplifier.

Fig. 1 shows a block diagram of the electromyogram circuit with the pre-amps and differential amplifier that you will build in this lab. You will connect the output voltage, v_3 , to an oscilloscope to record an EMG.

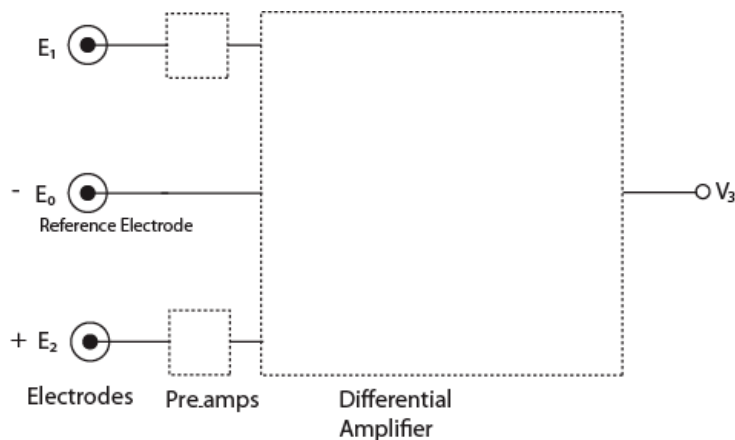

Figure 1. Block diagram of electromyogram circuit.

V. DEMONSTRATING THE NEED FOR PRE-AMPS

A. Rationale

In this part of the lab, you will demonstrate that using the electrodes to directly drive the differential amplifier would result in signals too small to be accurately measured. This scenario is similar to considering what would happen if we tried to use a 12V camera battery instead a car battery to start a car—the smaller battery would be unable to supply enough current to the starter motor, and output voltage of the small battery would drop to almost 0 V.

B. Procedure

Using the lower half of your breadboard (to avoid the already constructed pre-amp circuit), construct the voltage-divider circuit shown in Fig. 2. This circuit models the electrode driving a differential amplifier without a pre-amp. The $1\text{ M}\Omega$ resistor simulates the resistance between the muscle fibers and the electrodes, including the skin, which has high resistance. The $1\text{ k}\Omega$ resistor simulates the input of the differential amplifier.

In place of the electrode, use the 6V power supply in the same power supply used to power the pre-amps. (The 6V power supply is the third of three voltage sources in the power supply. To

see its value it, press the 6V button on the front of the power supply. Use the gray knob to adjust its value. The 6V outputs are the two leftmost banana plugs on the front panel of the power supply.) Use long wires coming off the breadboard and banana-to-alligator clips to connect to the 6V power supply. Adjust the 6V power supply to the values shown in Table II and use the multimeter probes to measure the voltage drop across R_2 . (Use the DCV button on the multimeter so the meter is reading voltage.) Record the measured voltage drop across R_2 in the second column of Table II. When you have completed the second column of Table II, use the voltage-divider formula from class to fill in the third column of Table II. Be sure to record what you are doing, including the voltage-divider formula, in your notebook.

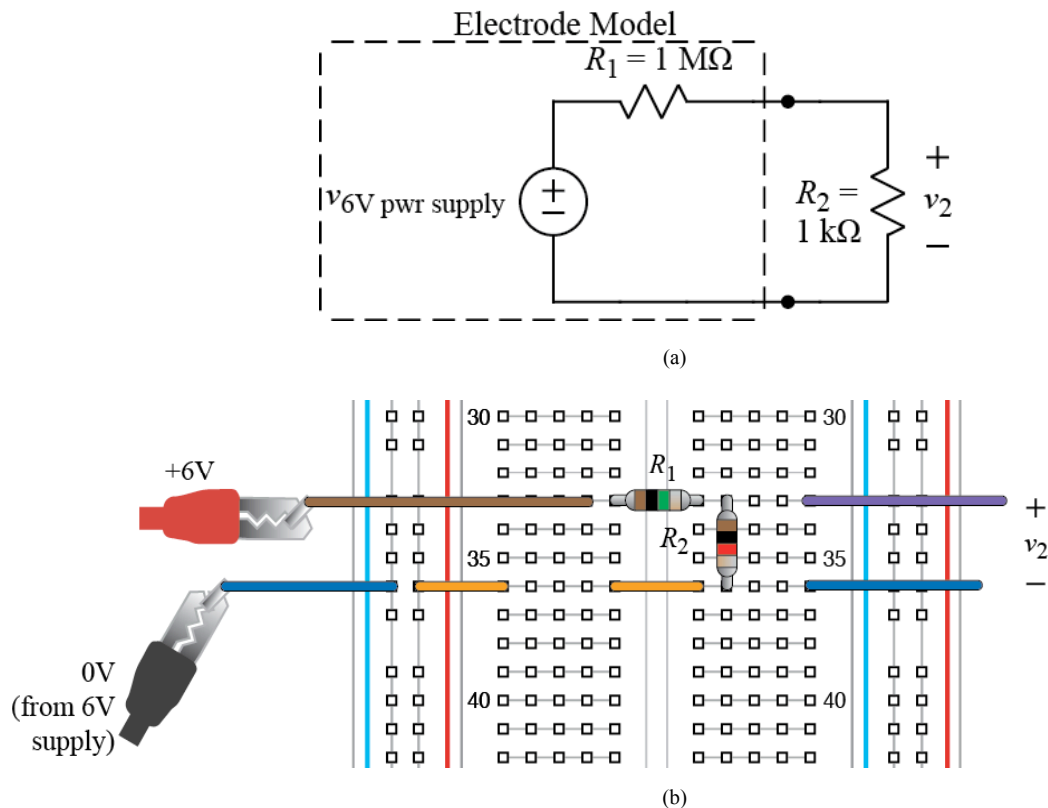

Figure 2. Circuit model of an electrode driving differential amplifier: (a) schematic, (b) breadboard layout.

TABLE II-A
MODEL OF ELECTRODE DRIVING DIFFERENTIAL AMPLIFIER

Power Supply Voltage	R_2 Voltage
0 V	
2 V	
4 V	
6 V	

Repeat the above process using the circuit shown in Fig. 3 and Table III. In this circuit, the 6V power supply and the 10Ω resistor simulate the output of the pre-amp. As before, R_2 simulates the input of the differential amplifier.

When you have filled out Tables II and III, determine which circuit gives an output that is closer to the value of the input voltage from the 6V power supply. Comment in your lab notebook on the results and explain why the pre-amps are needed in the EMG circuit. Note that,

when used for an actual EMG, the input signal to the circuit will only be a few millivolts instead of the higher values used here. If the signals get much smaller, they sink below the measurement noise.

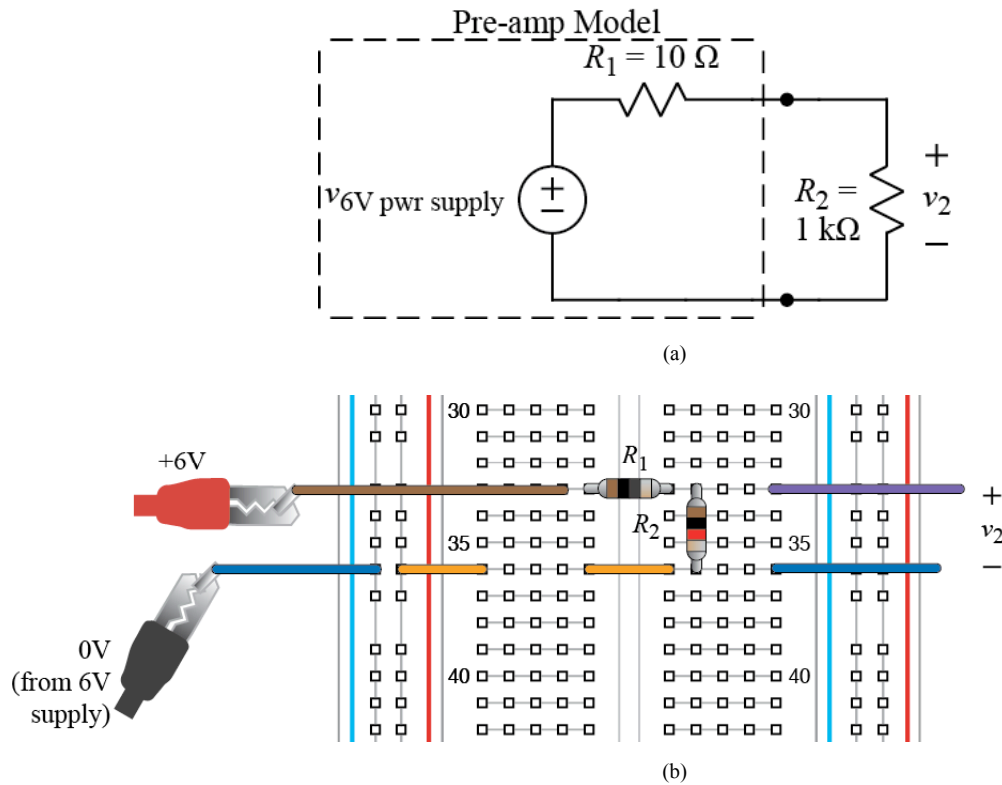

Figure 3. Circuit model of a pre-amp driving differential amplifier: (a) schematic, (b) breadboard layout.

TABLE II-B
MODEL OF PRE-AMP DRIVING DIFFERENTIAL AMPLIFIER

Power Supply Voltage	R_2 Voltage
0 V	
2 V	
4 V	
6 V	

VI. DERIVING AN EXPRESSION FOR THE DIFFERENTIAL AMPLIFIER OUTPUT

In this part of the lab, you will use the voltage-divider formula to derive an expression for the output voltage of the differential amplifier circuit shown in Fig. 4. Note that the power supplies for the op-amp are omitted from the schematic, but +12 V must be connected to pin 8 and -12V must be connected to pin 4 of a second op-amp chip used for the differential amplifier. Also, the wire to the reference electrode must be connected to the reference in your circuit, which is connected to the "common" output for the +25V and -25V supplies. (The reference is also where the black leads for oscilloscope probes and the function generator are connected.)

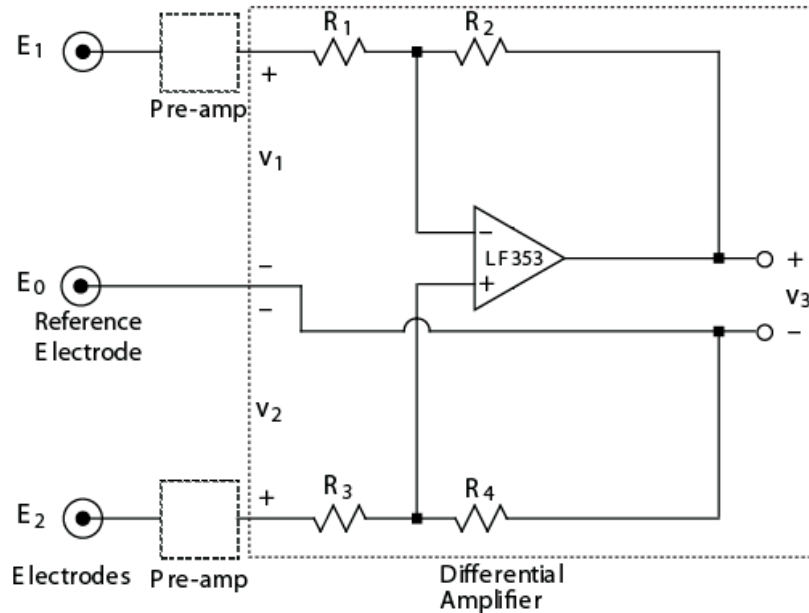

Figure 4. Schematic diagram of differential amplifier.

A. Deriving the Expression for v_3

When the output of an op-amp is connected back to the "-" input via a resistor, the op-amp output effectively adjusts to make the voltage drop across the + and - inputs zero. This is referred to as negative feedback. It is possible to show that this occurs because the op-amp output voltage is a large multiple of the voltage drop across the + and - inputs. We omit this analysis here, owing to its relative complexity, and we just assume that the voltage drop across the + and - inputs is zero. Using this assumption, we can find an expression for the output voltage of the op-amp, (i.e., v_3), as a function of electrode voltages, v_1 and v_2 , by the following procedure:

- 1) Use the circuit model in Fig. 5(a) and the voltage-divider formula to find voltage drop v_+ across R_4 .
- 2) Use the circuit model in Fig. 5(b) and Kirchhoff's and Ohm's law to find voltage drop v_- across R_2 and v_3 . In other words, v_- is the sum of the voltage drops across R_2 and v_3 .
- 3) Use a voltage loop to show that, if voltage drop across the + and - inputs equals 0 V, then $v_+ = v_-$.
- 4) Set $v_+ = v_-$ and solve for v_3 in terms of v_1 and v_2 .

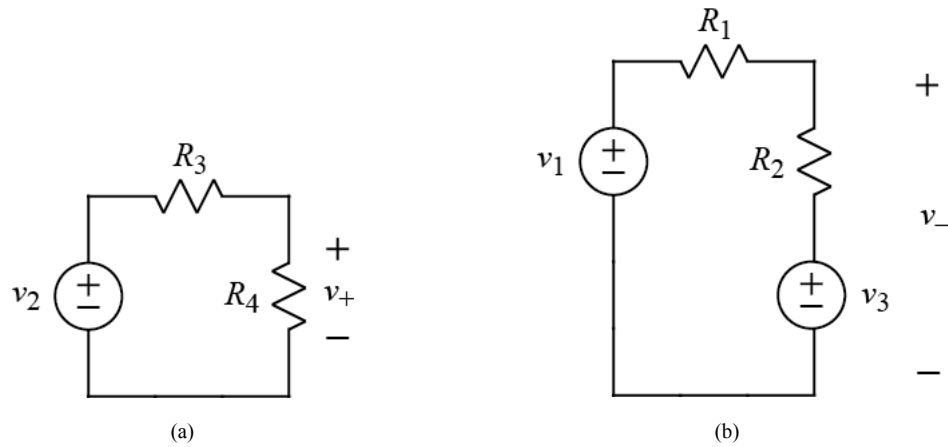

Figure 5. Sub circuits for analyzing differential amplifier: (a) v_+ value, (b) v_- value.

Armed with the expression for v_3 , we can now show that the differential amplifier may be designed to amplify only the difference in voltages v_1 and v_2 , thus reducing noise in the EMG measurements.

B. Differential Gain

We want v_3 to be proportional to only the difference (v_{dm} for "differential mode voltage") between v_1 and v_2 . This is helpful because any offset voltage (v_{cm} for "common mode voltage") common to both electrodes that is caused by a source other than nerve and muscle activity will be cancelled out. (Furthermore, electronic noise generated by non-ideal characteristics in our circuit will typically be the same for both electrodes and will be cancelled out.) The differential and common-mode voltages are defined as follows:

$$v_{cm} \equiv \frac{(v_2 + v_1)}{2} \quad (1)$$

$$v_{dm} \equiv v_2 - v_1 \quad (2)$$

To determine how to make the common-mode response (or gain) zero, rewrite the formula for v_3 in terms of the common-mode signal, v_{cm} , and the differential-mode signal, v_{dm} , defined in (1) and (2). Begin this process by making the following substitutions:

$$v_1 = v_{cm} - \frac{v_{dm}}{2} \quad (3)$$

$$v_2 = v_{cm} + \frac{v_{dm}}{2} \quad (4)$$

Now show that v_3 is a function of only v_{dm} if the ratio of R_1 to R_2 is the same as the ratio of R_3 to R_4 . To do so, first rewrite v_3 in terms of the following ratio, \mathfrak{R} :

$$\mathfrak{R} = \frac{R_1}{R_2} = \frac{R_3}{R_4} \quad (5)$$

(Note that it may be helpful to consider the reciprocals of expressions in order to express them in terms of \mathfrak{R} .) Then show that v_{cm} disappears from the expression for v_3 . Now that you have derived the expression for v_3 , you are ready to design the differential amplifier. That is, you are ready to find the values of R_1 through R_4 . Having found those values, you will build the circuit.

VII. DESIGNING, BUILDING, AND TESTING THE DIFFERENTIAL AMPLIFIER

In this part of the lab, you will complete the following tasks:

- 1) Determine the resistor values to use in the differential amplifier for a gain of 500.
- 2) Build and test the differential amplifier.
- 3) Measure the gain of the differential amplifier

A. Resistor values for a gain of 500

Keeping the preceding analysis in mind, design a differential amplifier for the electromyogram circuit that meets the following four design objectives:

- 1) The differential gain of the circuit is to be 500. The differential gain is the term multiplying v_{dm} in the equation for v_3 derived above. This makes the output as large as possible without causing the output to "saturate" by reaching the op-amp power supply voltages. (The output is limited by the power-supply voltages, resulting in clipping distortion of the output waveform if the voltage reaches the level of the power supply.)
- 2) The common mode gain of the circuit is to be zero.
- 3) The input resistances, R_1 and R_3 , are to be the same for both inputs. This will help cancel out less than ideal output characteristics of the pre-amps that might be amplified by any asymmetry in the differential amplifier's inputs.
- 4) The input resistances, R_1 and R_3 , must be high enough that the input current never exceeds the maximum current, (10 mA), that the op-amp in the pre-amp can supply. Use worst-case op-amp output voltage $v_o = +12$ V to determine the minimum R allowed. (Note that actual voltages out of our pre-amps will be small, and exact values are unknown.)
- 5) The maximum resistor values used in your circuit (R_1 , R_2 , R_3 , and R_4) should be limited to about 1 M Ω . This is because even a small noise current in our circuit can create a significant voltage across a high-valued resistor. Thus, we limit the resistor size in order to limit the voltage that small noise-currents will create.

List the values of R_1 , R_2 , R_3 , and R_4 prominently in your lab notebook.

B. Building and Testing the Differential Amplifier

The complete EMG circuit is shown in Fig. 6 but with resistor values missing. Using the layout in Fig. 6, draw a schematic diagram of the complete EMG circuit. Compare your result with Fig. 4 to determine which resistor is which in the differential amplifier. Also, include the circuit for the unused fourth op-amp on your schematic. What does this circuit do?

Your next task is to build and test the differential amplifier. Because the circuit has a high gain, the circuit must be tested with small input voltages. Fig. 7 shows how voltage dividers could be used to create small input voltages from power supply voltages of several volts. The resulting inputs to the pre-amps would mimic what the electrode signals look like. If enough power supplies were available, it would be possible to use the circuit shown in Fig. 7 to test both inputs at once. Since only one extra supply, (the 6V supply), is available, however, you will test your circuit using a voltage-divider on only one input at a time. The other input will be connected to reference.

It is up to you to decide how to layout the voltage divider on your breadboard for testing the EMG circuit. Use the 6V power supply to drive the voltage divider. Measure the differential-amplifier output voltage for several different input voltages for input 1. Then repeat the process for input 2. Make a table of the results in your lab notebook.

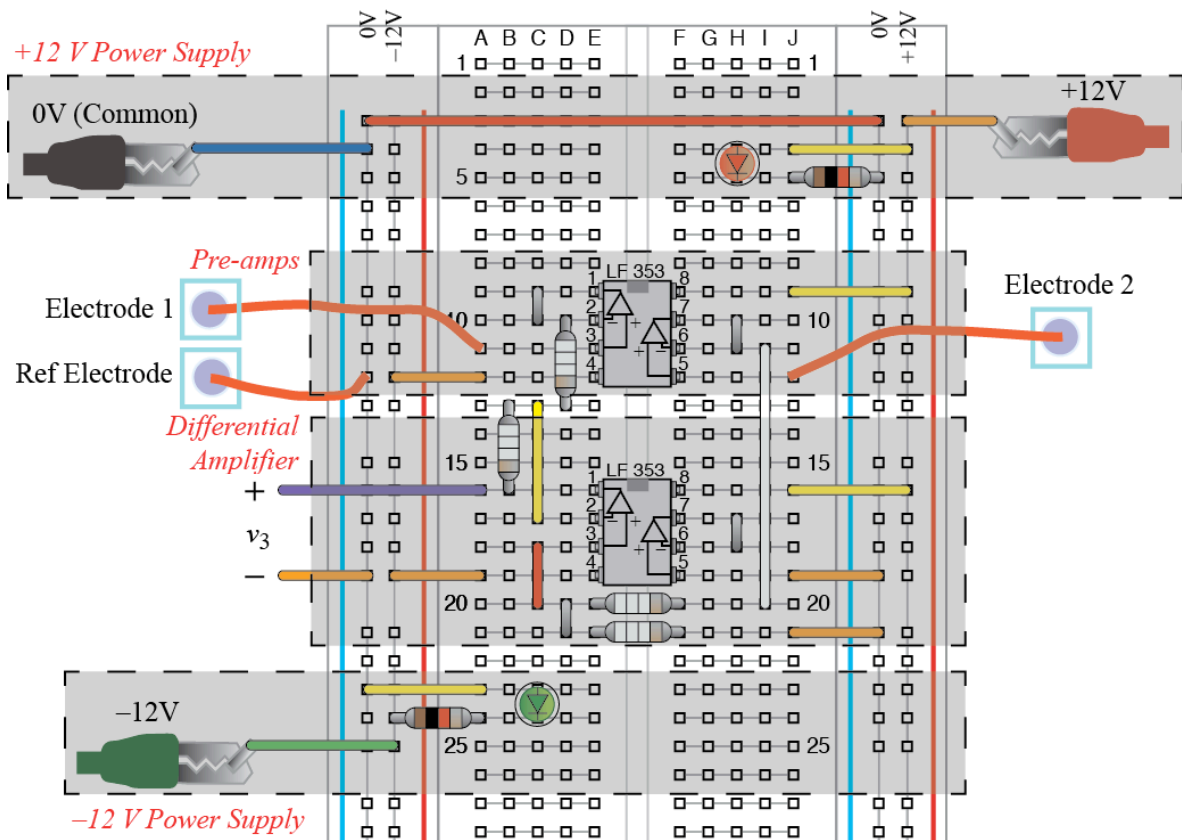

Figure 6. Complete EMG circuit.

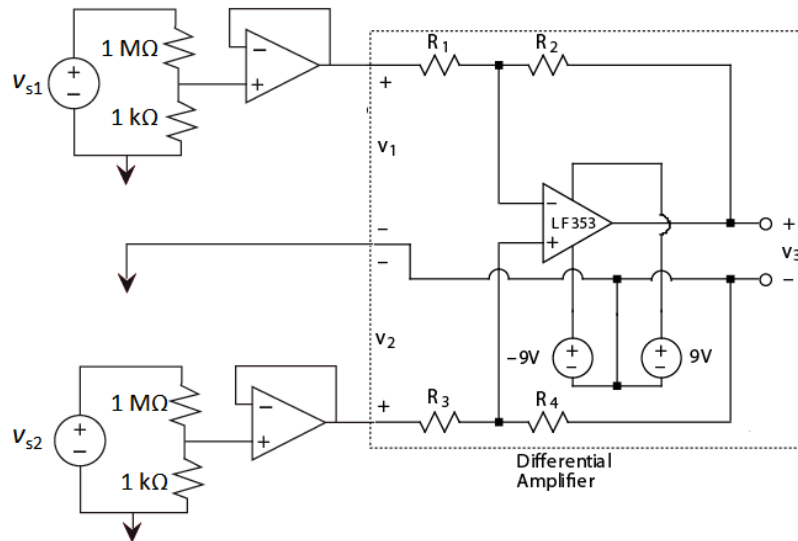

Figure 7. Testing differential amplifier using voltage dividers. (Arrow represents reference.)

C. Measuring the Gain of the Differential Amplifier

Verify that the gain of the differential amplifier is close to 500. To calculate the gain, use your previous measurements to make a plot of v_3 versus $v_2 - v_1$. Using the `polyfit` function in Matlab®, draw a straight line through the data and find the slope of the line. The slope is the gain of the circuit.

This method of calculating the gain eliminates a large constant offset in the output that results from an offset voltage across the + and – inputs of the op-amp in the differential amplifier. This offset voltage is only a few millivolts and represents the voltage across the + and – inputs that the op-amp interprets as exactly zero volts. In many applications this offset voltage may be neglected. In the differential amplifier circuit, however, the offset voltage is similar in size to the input signals and also gets multiplied by 500, causing a significant output voltage even when the two signals driving the differential amplifier are zero. A capacitor is used to eliminate this offset when measuring the EMG.

VIII. MEASURING AND ANALYZING EMG'S

In this part of the lab, you will complete the following tasks:

- 1) Connect electrodes to your biceps and measure EMG's while you are lifting various weights.
- 2) Plot and comment on the power in your EMG signal as a function of the weight lifted.

A. *Measuring EMG's*

As a safety precaution, use two 9 V batteries as the power supplies for your electromyogram circuit when measuring EMG's with actual electrodes. That is, replace the +12V and –12V power supplies with batteries.

Connect electrodes to your biceps—the muscle on the top of the upper arm that bulges when showing off your strength. Place two electrodes, measuring the voltages going into the preamps, about three inches apart, on the upper and lower end of the biceps slightly toward the outside of the muscle. Place the third, reference electrode, on the elbow. (Avoid placing the reference electrode on muscle.)

Connect the output of the electromyogram circuit to an oscilloscope. To eliminate the large constant vertical (DC) offset of the waveform, place a 0.1 μ F capacitor between the differential amplifier output and the oscilloscope probe. That is, attach the oscilloscope probe to one side of the capacitor and connect the other side of the capacitor to the differential amplifier output. Observe the waveform on the oscilloscope and capture an example of the waveform that you can plot in Matlab[®] on a computer. (See instructions under Matlab[®] on course website.) Print out copies of the waveform for both the lab notebook and report.

B. *Power versus Weight for EMG signals*

Write Matlab[®] code to calculate the average "power" of the recorded waveform by calculating the average value of voltage squared:

$$p = \frac{1}{N} \sum_{i=1}^N v_{3i}^2 \quad (6)$$

where

p is the average "power" of the EMG circuit output signal

N is the number of sample points

v_{3i} is the i th sample of the EMG circuit output voltage

(Note that p actually has units of voltage squared rather than power, but p is equal to the power we would have if we connected a 1 Ω resistor to the output of the circuit.)

C. *Plot of Electromyogram Power versus Weight*

Measure the average circuit output power, p , while holding the lower arm horizontal with no weight, one unit of weight, two units of weight, and three units of weight. Choose weights such that the three-unit weight requires significant but comfortable effort when held with the lower

arm horizontal. When performing the tests with weights, keep your joints in a constant position as much as possible.

Using Matlab[®], make a plot of p versus weight. Comment on the shape of this plot.

IX. NOTEBOOK AND REPORT

Turn in a copy of your laboratory notebook pages and a separate formal report. Refer to the grading information on the course website for the section numbering to use while writing the formal report. Use the IEEE format for typesetting. Information about the IEEE format, including a template file, is available on the course website. Additional information about writing the report and keeping a notebook is listed in the *Course Procedure* on the course website. Note that Matlab[®] plots, if there are any, must appear both in the laboratory notebook *and* the formal report.

X. ACKNOWLEDGMENT

K. Furse assisted in the writing of this handout.